



Grant Agreement No.: 723576

DryFiciency

Waste Heat Recovery in Industrial Drying Processes

H2020-EE-2016-2017-PPP

Valorisation of waste heat in industrial systems (SPIRE PPP)

Integrated Heat Pump Systems

D4.3

This is a Deliverable of WP4

Deliverable Leader: Veronika Wilk

Authors: Annemarie Schneeberger, Franz Helminger, Michael Bantle

Project co-funded by the European Commission within H2020 Programme

TABLE OF CONTENTS

EXECUTIVE SUMMARY	4
1 INTRODUCTION.....	4
2 CLOSED LOOP HEAT PUMP DEMONSTRATORS.....	5
2.1 Agrana	7
2.1.1 Integration layout for the starch drying process.....	7
2.1.2 Integration infrastructure for the closed loop heat pump	8
2.1.3 Heat Pump Demonstrator	10
2.2 Wienerberger	14
2.2.1 Integration layout for the brick drying process	14
2.2.2 Integration infrastructure for the closed loop heat pump	15
2.2.3 Heat Pump Demonstrator	17
3 OPEN LOOP HEAT PUMP DEMONSTRATOR	20
3.1.1 Integration layout for the sludge drying process	21
3.1.2 Integration infrastructure for the open loop heat pump.....	22
3.1.3 Open Loop Heat Pump Demonstrator	24
4 CONCLUSIONS.....	26
4.1 Closed Loop.....	26
4.2 Open Loop	26

Statement of originality:

This deliverable contains original unpublished work except where clearly indicated otherwise. Acknowledgement of previously published material and of the work of others has been made through **appropriate** citation, quotation or both.

NOTES: For comments / suggestions / contributions to this document, contact: Leader for this Deliverable and project coordinator email at Veronika.Wilk@ait.ac.at. For more information on the project DryFiciency, link to www.dryficiency.eu

List of abbreviations

AT	Austria
GWP	Global Warming Potential
HFO	Hydrofluoro-Olefin
MVR	Mechanical Vapor Recompression

List of Figures

Figure 1: Closed loop heat pumps and their innovations	5
Figure 2: Schematic integration layout for the heat pump assisted starch dryer	7
Figure 3: Positioning of the heat pump demonstrator	8
Figure 4: Internal piping	8
Figure 5: Pressure-maintaining device	8
Figure 6: Circulation Pump	9
Figure 7: Integration of Water-to-air heat exchanger	9
Figure 8: Piping/connections on the outside of the Agrana factory (left: without the heat pump demonstrator, right: including the container of the heat pump demonstrator)	9
Figure 9: Heat Pump Demonstrator for starch drying at Agrana	10
Figure 10: Bitzer compressor (left: before delivery; right: integrated in heat pump demonstrator)	11
Figure 11: Refrigerant container and level indicator	12
Figure 12: Oil separator	12
Figure 13: Oil cooler	12
Figure 14: Switch cabinet	13
Figure 15: Schematic integration layout for the heat pump assisted brick dryer	14
Figure 16: Positioning of the heat pump container on a newly built platform	15
Figure 17: Lifting heat pump container	15
Figure 18: Positioning heat pump at the platform	15
Figure 19: Piping for heating coils	16
Figure 20: Hot water cycle	16
Figure 21: Pressure holding device incl. circulating pump	16
Figure 22: Air register	16
Figure 23: Connection pipes of the heat recovery cycle to the heat pump container	16
Figure 24: Heat Pump Container (outside)	17
Figure 25: Heat Pump Container (inside)	17
Figure 26: Viking Heat Engines compressor (left: single unit; right: integrated in heat pump demonstrator) .	18
Figure 27: Refrigerant distributor	19
Figure 28: Switch cabinet	19
Figure 24: Open loop heat pump and their innovations	20
Figure 30: Schematic integration layout of MVR-dryer for sludge drying	21
Figure 31: Placement of the open loop heat pump at the Scanship demosite	22
Figure 32: Inverter for power supply to the compressors: stage one with 135 kW and stage two with 75 kW	23
Figure 33: Power supply for the open loop heat pump system.	23
Figure 31: The jacket of the SHS-drier operates as MVR heat exchanger for the open loop heat pump. Picture is taken before mounting the SHS-drier.	24
Figure 34: The two EA42 turbo-compressors from Rotrex mounted in the open loop heat pump (left). The cooling system requires only a water connection (top right) and not an external oil cooling system like the EC38 model (down right).	25
Figure 35: Flexible adjustment of the inlet and outlet of the EA42 unit enables standard connections (left), while the EC38 model needs a specially welded connection arrangement (right).	25
Figure 36: Bed of metal packings for improved and more compact de-superheating between compressor stage 1 and compressor stage 2.	26

EXECUTIVE SUMMARY

Deliverable D4.3 “*Integrated Heat Pump Systems*” is the third deliverable of work package 4, which aims at planning, constructing and commissioning three integrated heat pump demonstrators for each of the processes, starch, brick and sludge drying.

It describes the finally constructed two closed loop and the open loop heat pump demonstrators and their integration into the respective drying process. The results of the first test runs and the commissioning of the three heat pump demonstrators will be reported in deliverable D4.4 “*Protocol of first test run and signing off document*”.

1 INTRODUCTION

The focus of the DryFiciency project is **to develop and implement cost-efficient high temperature heat pump solutions for industrial thermal drying processes**. Industrial drying and dehydration processes require intensive use of energy, and estimates show that 12-25% of the national industrial energy consumption in developed countries is attributable to industrial drying. Currently, most of this energy is based on the use of fossil fuels with no utilization of waste heat streams. Hence, there is a great potential for more efficient and environment-friendly technologies within industrial drying processes. The development of such technologies is also of relevance for a number of other industrial sectors, such as the petro-chemical industry and the pulp and paper industry.

Three different industrial drying processes are considered in the project. These are applications and developments of thermal drying in the **agricultural raw material industry**, in the **ceramic industry** and in the **waste management industry**. In the agricultural raw material application, the heat pump technology will be developed for the production and drying of starch from potatoes, wheat and corn. The demonstration of this heat pump system will take place at Agrana Stärke GmbH in Pischelsdorf, Austria. For the application in the ceramic sector, the focus is to integrate novel heat pump technology for green brick drying. This technology will be implemented by Wienerberger AG at Uttendorf, Austria. Finally, the application for the waste management industry focuses on the drying of sludge/biomass. This heat pump drying system will be developed and installed by Scanship, Norway.

To utilize the waste heat streams of the above drying processes, **three advanced high-temperature heat pump systems** are developed:

1. Two **closed loop cycle** systems based on the low global warming potential (GWP) refrigerant HFO-1336mzz-Z with good thermodynamic properties at the identified drying temperatures. Thus, the closed loop heat pump system is suitable for supply temperatures up to 160°C. The closed loop cycle is for convective air drying and will be integrated into the dryers for starch (Agrana Stärke GmbH) and bricks (Wienerberger AG).
2. One **open loop cycle** system, where water (R718) is the refrigerant. Such systems are commonly referred to as MVR (Mechanical Vapour Re-compression). In this system, the heat pump cycle directly utilizes the excess steam from the dryer. The open loop cycle for convective superheated steam drying will be integrated into dryers for sludge (Scanship AS) using a novel turbo-compression technology.

2 CLOSED LOOP HEAT PUMP DEMONSTRATORS

Closed loop heat pump systems, also known as **compression heat pumps**, compress a working media, so called refrigerants, to higher temperature levels at the heat consumer (heat sink) than at the heat source. They **deliver a much higher amount of energy (heat) than** the amount of energy (usually electricity) **needed for their operation**. Therefore, they are highly efficient waste heat recovery devices.

Compression heat pumps consist of **four main components: compressor, condenser, expansion valve and evaporator**. They make use of a wide variety of working media (refrigerants), which are kept within a continuous loop at all times (closed loop). In the evaporator, the refrigerant is exposed to the heat source (e.g. industrial waste heat). There, the refrigerant evaporates at low pressure and low temperature. The compressor increases the pressure of the refrigerant to a higher pressure level. In the condenser, the energy of the working fluid (refrigerant) is transferred to a distribution medium (e.g. water, air) or a heat consumer. The refrigerant is cooled and becomes liquid again. In order to close the heat pump loop, the working fluid is fed into an expansion valve, where the pressure is reduced. The low pressure low temperature liquid is ready to enter the evaporator again.

In DryFiciency, high temperature heat pumps supplying **process heat up to 160°C** are being developed and **industrially demonstrated for the first time**. The DryFiciency consortium has worked on **several important innovations** for that purpose as displayed in Figure 1 and described in more detail below.

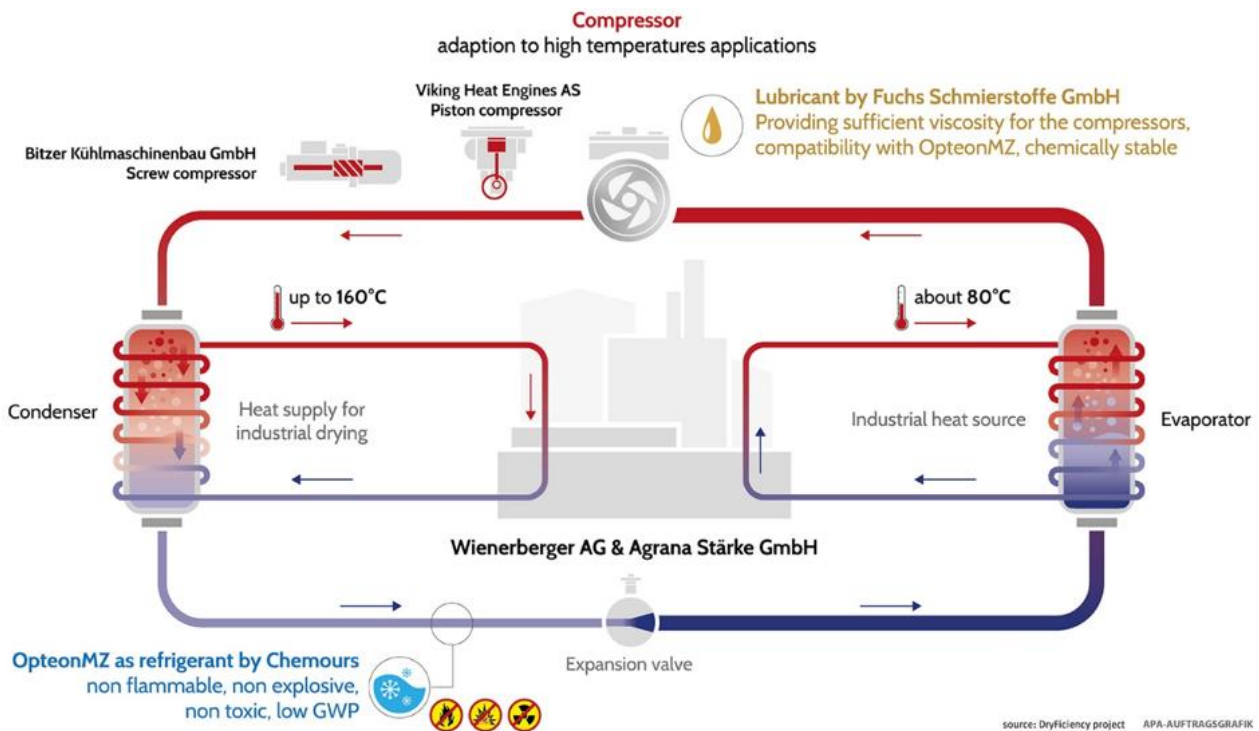

Figure 1: Closed loop heat pumps and their innovations

The main innovations on component level include:



Viking Heat Engines

Two novel compressor technologies, screw compressors by Bitzer Kühlmaschinenbau GmbH (www.bitzer.de) from Germany and piston compressors by the Norwegian Viking Heat Engines (www.vikingheatengines.com).

They are both described in more detail in section 2.1.3 (screw compressors) respectively 2.2.3 (piston compressors).



Use of **Opteon^{TM1} MZ** from Chemours (www.chemours.com) as refrigerant. This synthetic refrigerant based on HFO (hydrofluoro-olefin) was developed for high temperature applications with heat supply temperatures of up to 160°C, as envisaged by DryFiciency. It has a low GWP (Global Warming Potential) of 2 and shows a number of favourable characteristics: it is non-flammable, non-toxic and not subject to the F-gas regulation.



A **unique synthetic lubricant** for high temperature applications developed by FUCHS (www.fuchs.com) for both compressors, which remains chemically and thermally stable when operated with the refrigerant selected, OpteonTM MZ from Chemours, at elevated temperature levels.

Both two closed loop heat pump systems are realised as **twin-cycle configurations with two refrigerant cycles**. This configuration is on the one hand more efficient when dealing with a wide operating range. On the other hand, it offers advantages in terms of start-up behaviour and approval due to the lower refrigerant charge per circuit.

The two heat pump systems are integrated in **air drying processes** that are currently heated with natural gas. At both industrial sites, waste heat from other drying processes is available. Thus, heat recovery water cycles serve as heat source for the two heat pumps. The heat sink is the drying agent (air), which is heated in a heat exchanger and provides energy for the drying processes. Thus, the natural gas consumption is substituted by a considerably smaller amount of electricity.

In the following chapters, the two closed loop heat pump demonstrators are described in more detail providing also information on their integration layouts, and their integration infrastructures required.

¹ Or HFO-1336mzz-Z

2.1 Agrana

Agrana (www.agrana.com) is a leading Austrian company adding value to agricultural commodities by producing a wide range of industrial products for the processing sector. It operates many dryers in its 54 sugar and starch factories for product and by-product drying, which are currently mainly fossil-fired, although heat recovery options are being implemented wherever feasible. In DryFiciency Agrana makes major steps towards increasing the share of renewable energy in Agrana's production facilities, by implementing a novel closed loop heat pump system in one of the company's starch drying process at the production site of Agrana Starch GmbH in Pischelsdorf (AT).

The Agrana heat pump demonstrator has a heating capacity of approx. 400 kW, which is about 10% of the starch dryer's heat demand. The heat supply temperatures are in the range of 110 to 160°C. The demonstrator shall decrease the end energy consumption by 2,200 MWh/a, and shall lead to a reduction in CO₂ emissions of 500 t/a.

2.1.1 Integration layout for the starch drying process

The starch drying process is a continuous process with an integrated closed loop heat pump system, as shown in Figure 2. The drying agent (air) is preheated by a water-to-air heat exchanger from a heat recovery cycle with water as heat transfer fluid. After this initial preheating, the water also serves as the source for the evaporator of the heat pump system. The inlet temperature is then ≈70°C. At the condenser side, high temperature heat is released to the drying agent via an intermediate water circuit and a water-to-air heat exchanger. The heat supply temperature of the heat pump is up to 160°C and is measured at the outlet of the condenser in the intermediate water circuit. Due to the heat pump, less energy is needed in the last heat exchanger that is heated with steam to reach a desired temperature level of ≈160°C at the inlet of the flow stream dryer.

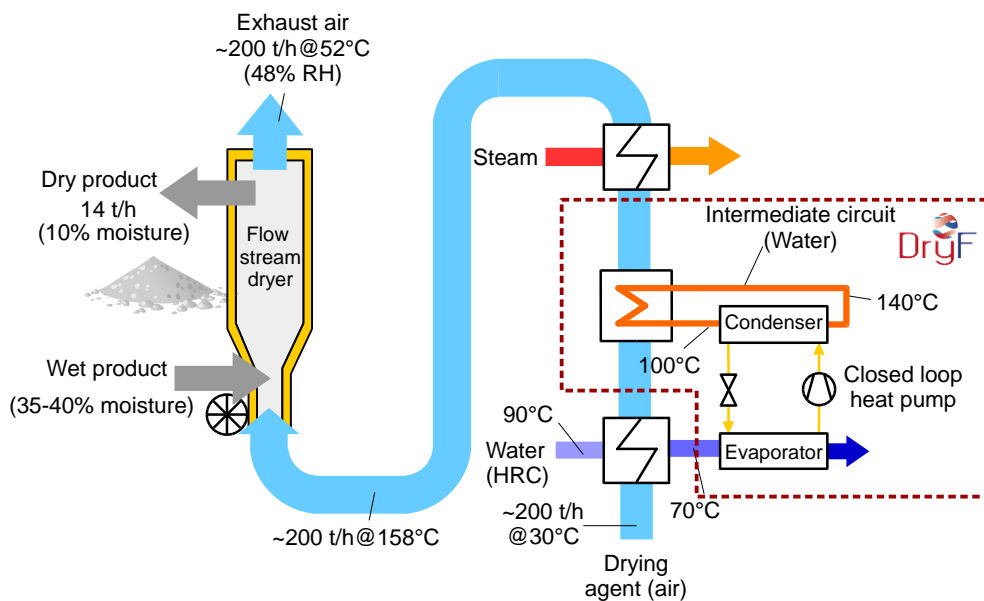

Figure 2: Schematic integration layout for the heat pump assisted starch dryer

2.1.2 Integration infrastructure for the closed loop heat pump

The container with the heat pump has a size of 8.5 m (length), 2.845 m (height) and 2.7 m (width). Due to the space requirements, it was decided in an early phase of the project, to place the container outdoors the Agrana production facilities, as displayed in Figure 3. Hence, Agrana had to conduct installation and engineering work in- and outdoors to prepare for the integration of the heat pump into its starch drying process.

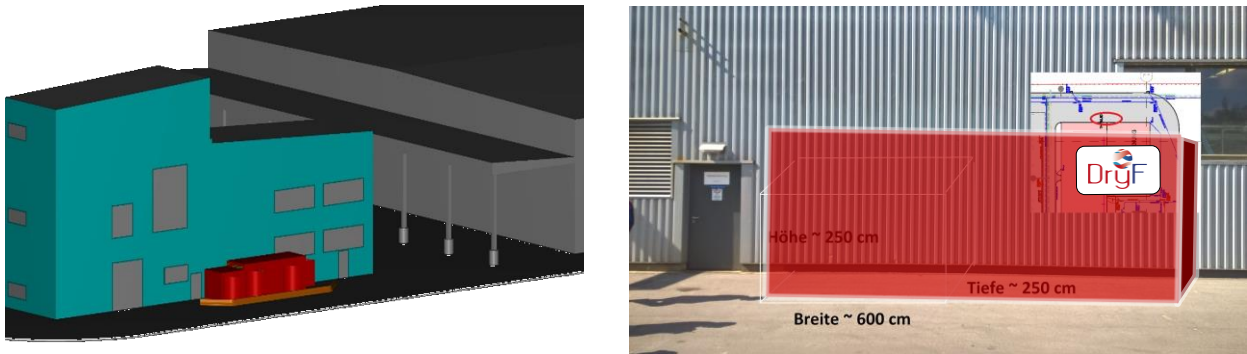

Figure 3: Positioning of the heat pump demonstrator

The indoor integration infrastructure includes piping (Figure 4), a pressure-maintaining device (Figure 5), a circulation pump (Figure 6), and a water-to-air heat exchanger (Figure 7).



Figure 4: Internal piping



Figure 5: Pressure-maintaining device

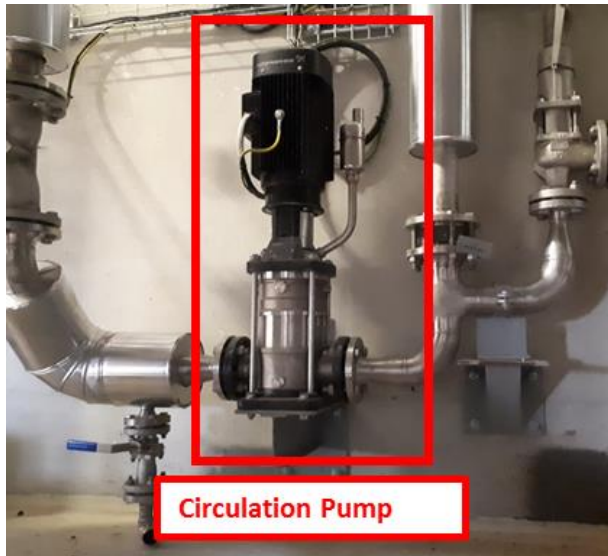

Figure 6: Circulation Pump

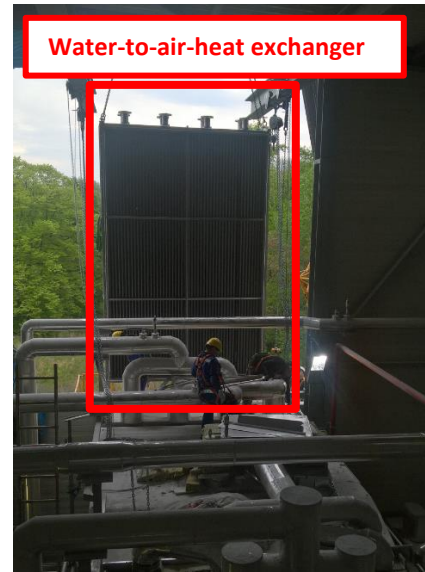

Figure 7: Integration of Water-to-air heat exchanger

Furthermore, the piping of the hot and cold side had to be extended to the outside of Agrana's production building to connect it to the heat pump container (Figure 8)



Figure 8: Piping/connections on the outside of the Agrana factory (left: without the heat pump demonstrator, right: including the container of the heat pump demonstrator)

2.1.3 Heat Pump Demonstrator

The heat pump container depicted in Figure 9² sized 8.5 m (length), 2.845 m (height) and 2.7 m (width) is equipped with eight doors (four in the front, two in the back, two doors sideways for the switch cabinet room) to enable easy access, and if required, replacement of single parts of the heat pump. To fit Agrana's corporate identity it is painted in grey. Besides the heat pump itself, the container is also equipped with all connections/piping to connect the heat pump to Agrana's starch drying process (see Figure 8).

The heat pump consists of hundreds of single parts, covered in the following main component categories:

- *Components for refrigerant circuits* including semi-hermetic screw compressors, condensers, evaporators, subcoolers, suction gas superheater, refrigerant receiver, and oil separators.
- *Components for water distribution for the heat source and heat sink* including control and safety valves, metal bellows compensator, etc.
- *Housing* including refrigeration machinery room equipment like ventilation, leakage detection system and warning devices.
- *Control system* including cabinet, programmable controller, frequency converters, electrical fuses, control transformer, visualisation, data logging and data transfer equipment to allow profound monitoring activities.
- *Measurement devices* including temperature sensors (32x), manometers (6x), pressure transmitters (18x), heat meters (3x), etc.

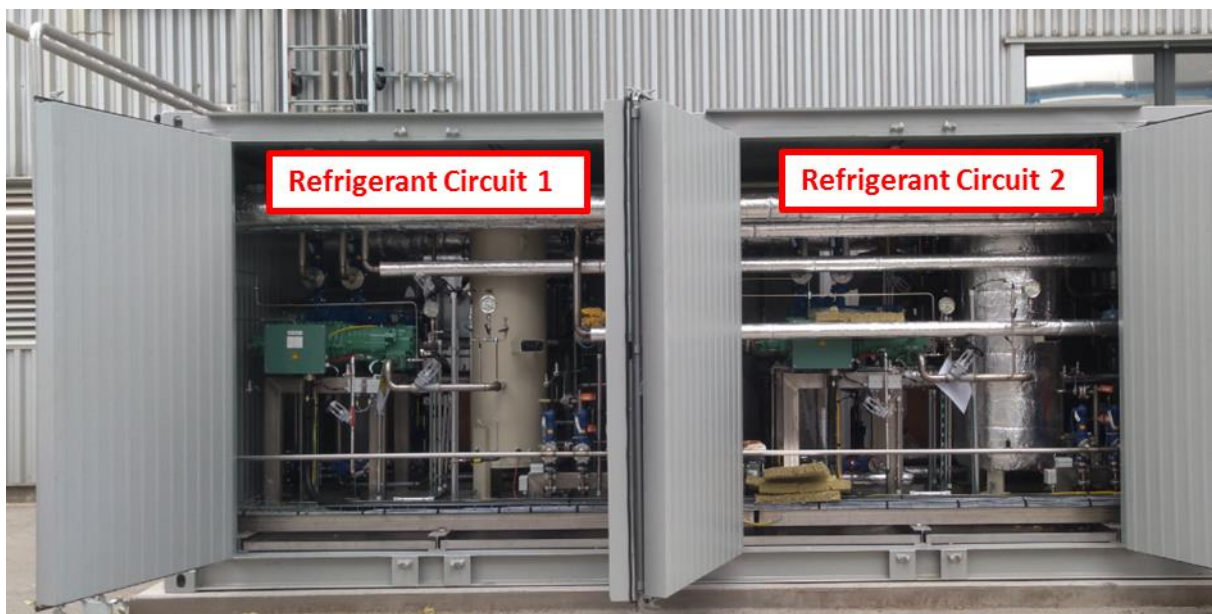

Figure 9: Heat Pump Demonstrator for starch drying at Agrana

Several components are either innovative or differentiate the Agrana closed loop heat pump demonstrator from the second closed loop heat pump demonstrator installed at Wienerberger. These parts, which will be presented in more detail, include:

² Figure 9 shows the heat pump before insulation work has been finished to allow good visibility of the components.

1. Adapted screw compressors
2. Refrigerant receiver with level indicator
3. Oil separator and cooler
4. Switch cabinet

1) Adapted screw compressors

The Agrana closed loop heat pump demonstrator is equipped with **two modified semi-hermetic screw compressors** (as displayed in Figure 10) developed and manufactured by the project partner Bitzer Kühlmaschinenbau GmbH (www.bitzer.de). They are based on the companies' **proven HS series**, which was adapted to be applied for suction gas temperatures up to 100°C and discharge temperatures of 160°C (state-of-the art: 100°C). The compressor has a two-shaft rotary displacement design with high efficiency profile geometry and a swept volume of 300 m³/h at 60 Hz operation frequency. Further key features include:

- Optimized for parallel operation with up to six compressors
- Optimal capacity adjustment and minimal energy requirements under full- and part-load
- Combination of various compressor sizes possible
- High efficiency rotor profile
- High efficiency suction gas cooled motor

To guarantee durability, miscibility, wear protection and viscosity required by the compressor, a novel lubricant developed and manufactured by Fuchs Schmierstoffe GmbH (www.fuchs.com) for the DryFiciency project is used.



Figure 10: Bitzer compressor (left: before delivery; right: integrated in heat pump demonstrator)

2) Refrigerant receiver with level indicator



Both refrigerant circuits of the Agrana heat pump are equipped with a level indicator to visually display the actual refrigerant level³ (see Figure 11), which differs according to the operating condition of the heat pump.

The detailed knowledge gained on the refrigerant level required will be used to optimize the dimensioning of the refrigerant receiver in future heat pump applications.

Figure 11: Refrigerant container and level indicator

3) Oil separator and cooler

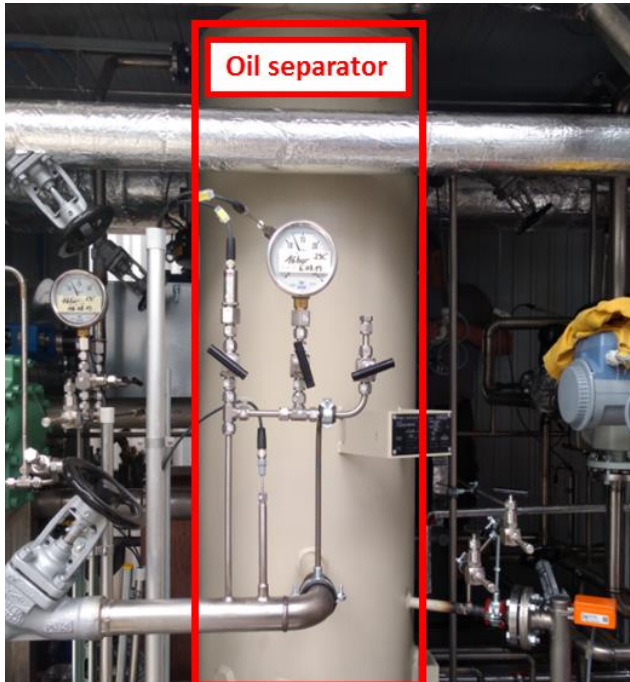

Figure 12: Oil separator



Figure 13: Oil cooler

³ The data on the refrigerant level is also gathered via sensors and analyzed accordingly.

The cylindrical oil separator shown in Figure 12 has a diameter (without insulation) of about 500 mm and a height of about 1600 mm and is required to separate the gaseous refrigerant and the liquid oil. It was designed according to the projects' requirements including an electrical heater for preheating the oil (e.g. for start-up), temperature sensors and minimum level monitoring.

A plate heat exchanger is used as oil cooler (see Figure 13). It is equipped with one heating coil to allow pre-heating for start-up. During operation the oil temperature is be limited to protect the compressor from being damaged.

4) Switch cabinet

The switch cabinet includes, amongst others, all electrical connections for the refrigerant circuits and the monitoring devices for the refrigeration room. To protect it from weather influences, it is put into a separate housing within Agrana's heat pump container to be accessed via a separate door.

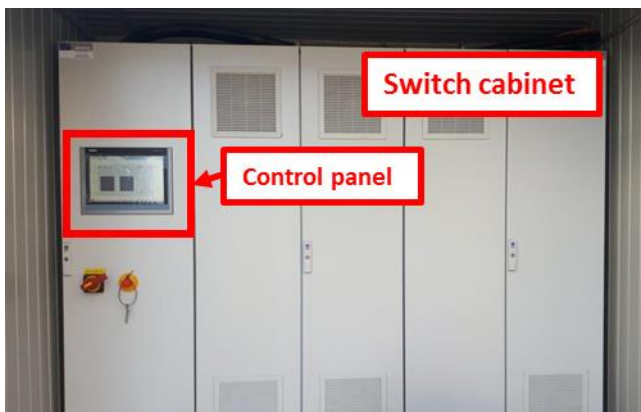

Figure 14: Switch cabinet

At the very left door of the switch cabinet, the main switch and control panel is integrated.

On the control panel the essential operating parameters of the demonstrator are shown. In manual mode, the control panel is used to control the demonstrator. In automatic mode, the control panel is used for monitoring.

2.2 Wienerberger

Wienerberger (www.wienerberger.com) is the world's largest producer of bricks and number one in the clay roof tiles market in Europe. The Austrian-based multinational company also holds leading positions in concrete pavers in CEE and pipe systems in Europe. The company operates approx. 200 brick dryers in its manufacturing units worldwide. Heat pump drying, as demonstrated in DryFiciency, at the production site in Uttendorf (AT) shall replace the actual fossil based combustion-driven drying technique in the future.

The heating capacity of the heat pump demonstrator, which is replacing a natural gas burner, is approx. 400 kW. The heat supply temperatures are in the range of 110 to 160°C. The anticipated energy savings add up to 84% of the current final energy demand and shall lead to a reduction in CO₂ emissions of about 80%.

2.2.1 Integration layout for the brick drying process

The brick drying process in DryFiciency is a continuous tunnel dryer as illustrated in Figure 15. Air is used as drying agent that flows counter-currently to the bricks. Bricks enter the dryer with 28% moisture and are dried to 2%. Drying air in the tunnel is heated by internal heat exchanger surfaces, which are supplied with water with 90°C by a heat recovery cycle. The heat pump also uses the heat recovery cycle as the heat source. The evaporator is integrated before the heat exchangers. The heat pump provides hot air via an intermediate circuit, heat supply temperatures up to 160°C can be reached there. The hot air is fed into the outlet zone of the tunnel dryer, where the highest temperatures are required. The heat pump acts as a booster for the heat recovery cycle.

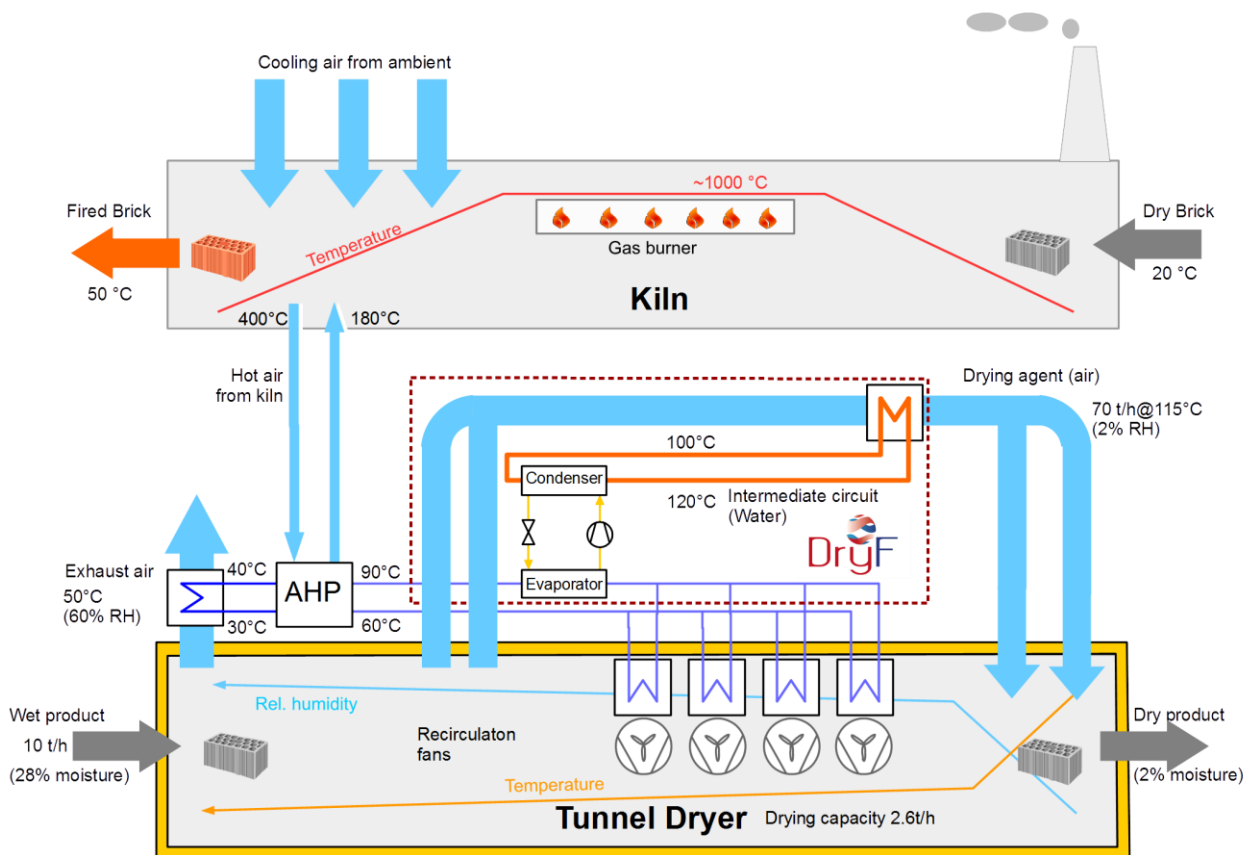

Figure 15: Schematic integration layout for the heat pump assisted brick dryer

2.2.2 Integration infrastructure for the closed loop heat pump

In contrary to Agrana, Wienerberger placed the container with the heat pump indoors. A platform was constructed in approximately 3 meter height (see Figure 16) to place the heat pump container just above the bricks moving from the tunnel dryer to the tunnel kiln.



Figure 16: Positioning of the heat pump container on a newly built platform

The sizing of the heat pump container - 6.8 m (length), 2.9 m (height) and 2.675 m (width) - and the spatial conditions at the production plant concerned, required opening of the roof of the Wienerberger production site to allow for lifting the heat pump container inside the Wienerberger factory with a crane (see Figure 17), and placing it on the newly built platform (see Figure 18).

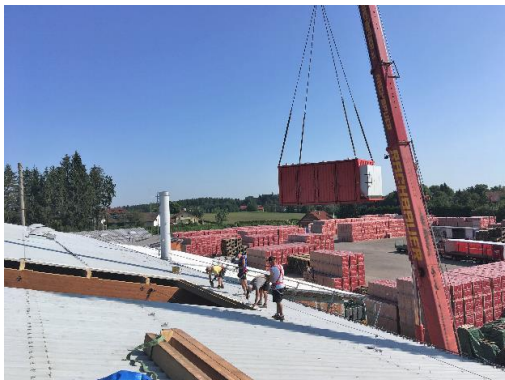

Figure 17: Lifting heat pump container

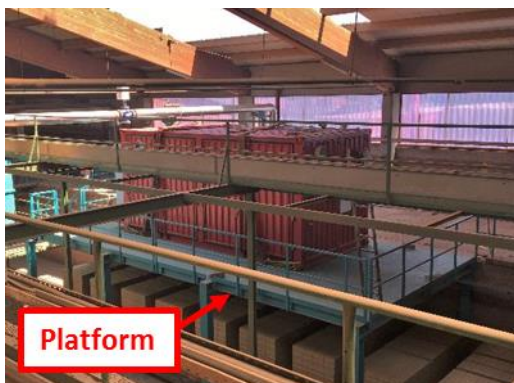

Figure 18: Positioning heat pump at the platform

The integration infrastructure at Wienerberger includes piping, electrical connections, the installation of a pressure holding device including circulation pump, and of a water-to-air heat exchanger (air register). Figure 19 to Figure 23 display the relevant infrastructure.



Figure 19: Piping for heating coils

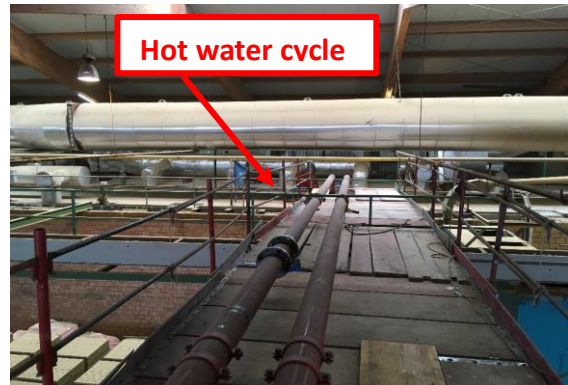

Figure 20: Hot water cycle

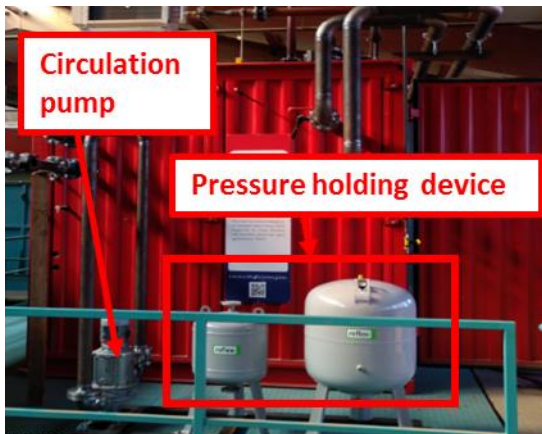

Figure 21: Pressure holding device incl. circulating pump



Figure 22: Air register

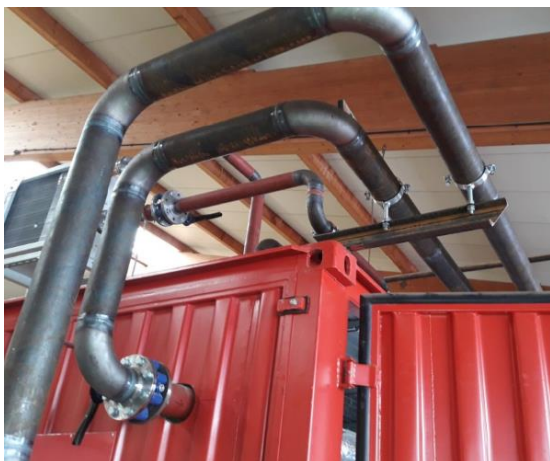

Figure 23: Connection pipes of the heat recovery cycle to the heat pump container

2.2.3 Heat Pump Demonstrator

As evident from Figure 24 and Figure 25, the Wienerberger heat pump container is also equipped with eight doors for accessing the heat pump and its components, but is painted in Wienerberger's company colour red. It contains all piping and other connections required for integrating the heat pump into the heat supply infrastructure for brick drying (see Figure 23).

The heat pump consists of hundreds of single parts, included in the following main component categories:

- *Components for refrigerant circuits* including piston compressors, condensers, evaporators, subcoolers, and refrigerant receiver.
- *Components for water distribution for the heat source and heat sink* including control and safety valves, metal bellows compensator, etc.
- *Housing* including refrigeration machinery room equipment like ventilation, leakage detection system and warning devices.
- *Control system* including cabinet, programmable controller, frequency converters, electrical fuses, control transformer, visualisation, data logging and data transfer equipment to allow profound monitoring activities.
- *Measurement devices* including temperature sensors (36x), manometers (6x), pressure transmitters (18x), heat meters (3x), etc.



Figure 24: Heat Pump Container (outside)



Figure 25: Heat Pump Container (inside)

Several components are either innovative or differentiate the Wienerberger closed loop heat pump demonstrator from the system integrated at Agrana, and are therefore presented in more detail. These parts include:

1. Novel piston compressors
2. Refrigerant receiver and distributor
3. Placement of switch cabinet

1) Novel piston compressors

The Wienerberger heat pump demonstrator is equipped with **eight piston compressors** (HBC 511) developed by project partner **Viking Heat Engines** (www.vikingheatengines.com) in collaboration with AVL. They are based on a proven, heavy-duty design, and are engineered to operate at very high internal temperatures and pressures (up to 215 °C). One piston compressor has a swept volume of 55 m³/h at 60 Hz. Further key features include:

- Very low internal friction through exclusive use of low-friction bearings
- Internal oil circuit with oil filter and preheater
- Hermetically sealed, highly efficient permanent magnet synchronous motor for variable speed control
- Water cooled motor for very high temperature applications with integrated thermal monitoring
- Optimized for parallel operation, where several compressors can run in parallel
- Multi-compressor phase synchronization for low vibrations and pulsations, if needed

This compressor technology, which is depicted in Figure 26 as single unit, but also integrated in one refrigeration circuit of the heat pump demonstrator, is compatible with all common refrigerants of the 3rd and 4th generations (e.g. HFOs) including the refrigerant used in the DryFiciency project from project partner Chemours (www.chemours.com). In DryFiciency, it is operated with a novel lubricant developed and manufactured by Fuchs Schmierstoffe GmbH (www.fuchs.com) as described.

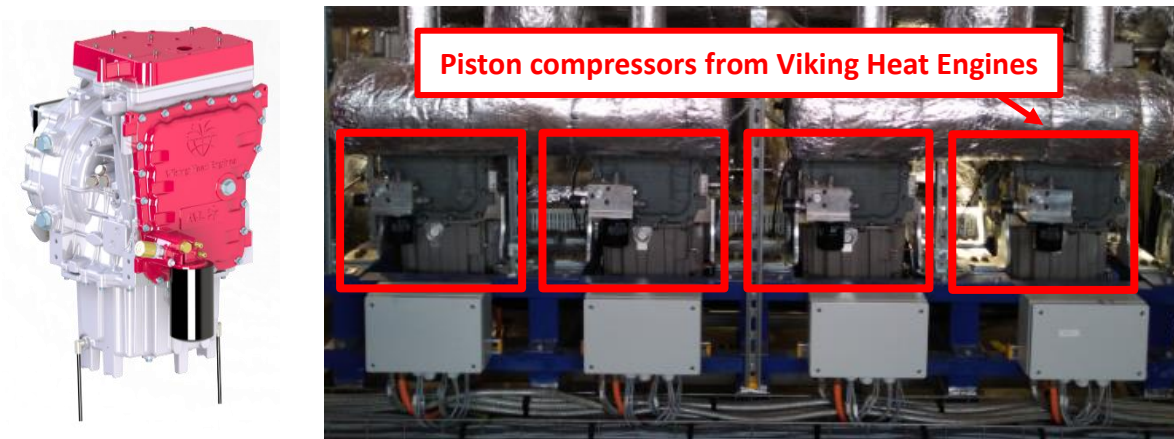
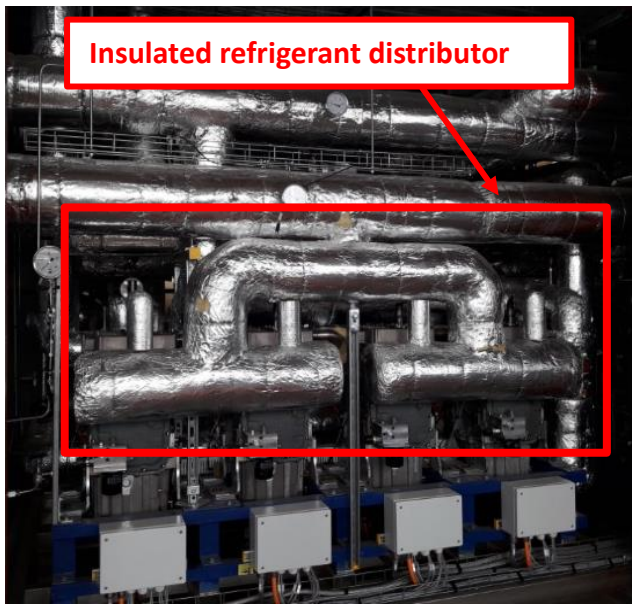

Figure 26: Viking Heat Engines compressor (left: single unit; right: integrated in heat pump demonstrator)

2) Refrigerant receiver and distributor



The refrigerant receiver is equipped with a minimum level monitoring system comparable to the Agrana demonstrator. This ensures that a minimum refrigerant level is contained in the refrigerant container.

The refrigerant distributor (suction side of the compressor) ensures that the same amount of refrigerant is fed into each compressor. Therefore all compressors have the same power consumption. A very different flow rate per compressor is unfavourable for the entire system, as it would result, e.g. in a reduction in capacity.

Figure 27: Refrigerant distributor

3) Placement of switch cabinet

The switch cabinet includes amongst others all main connections for the two refrigerant circuits and the monitoring devices for the refrigeration room.



At Wienerberger, it is placed outside the heat pump container. Protection against weather influences is not required, as the heat pump container is operated indoors.

The switch cabinet is equipped with four doors. At the very left door, the main switch and control panel is integrated.

On the control panel the essential operating parameters of the demonstrator are shown. In manual mode, the control panel is used to control the demonstrator. In automatic mode, the control panel is used for monitoring.

Figure 28: Switch cabinet

3 OPEN LOOP HEAT PUMP DEMONSTRATOR

Open loop heat pump systems also known as **Mechanical Vapour Recompression (MVR) systems** use **water as refrigerant** in steam drying processes. Water as refrigerant is easily available, non-toxic and represents no environmental hazard.

In the conventional steam drying processes, goods are dried in a steam atmosphere. The process steam is circulated and reheated by a natural gas burner. The water removed from the product is present in the form of excess steam. Usually, the excess steam cannot be used further because there is no heat demand at this temperature and it is therefore wasted. MVR systems allow for the use of the excess steam. Compressors increase the pressure level of the surplus steam to condense it at higher temperatures. A separate evaporator is not required, as the dryer acts as such.

The open loop heat pump system developed by the DryFiciency consortium uses **advanced, low-cost, turbo-compressor technology** originating from the automotive sector. It is further developed to reach condensation temperatures of up to 160°C at a combined pressure ratio of 6 when compressing steam over two stages. In the condenser, the hot excess steam reheats the process steam of the dryer. Thereby, the natural gas burner can be replaced.

Figure 29 shows the working principle of the open loop heat pump system with its innovative component, the oil-free steam turbo-compressor technology developed by Rotrex, integrated in a steam drying process.

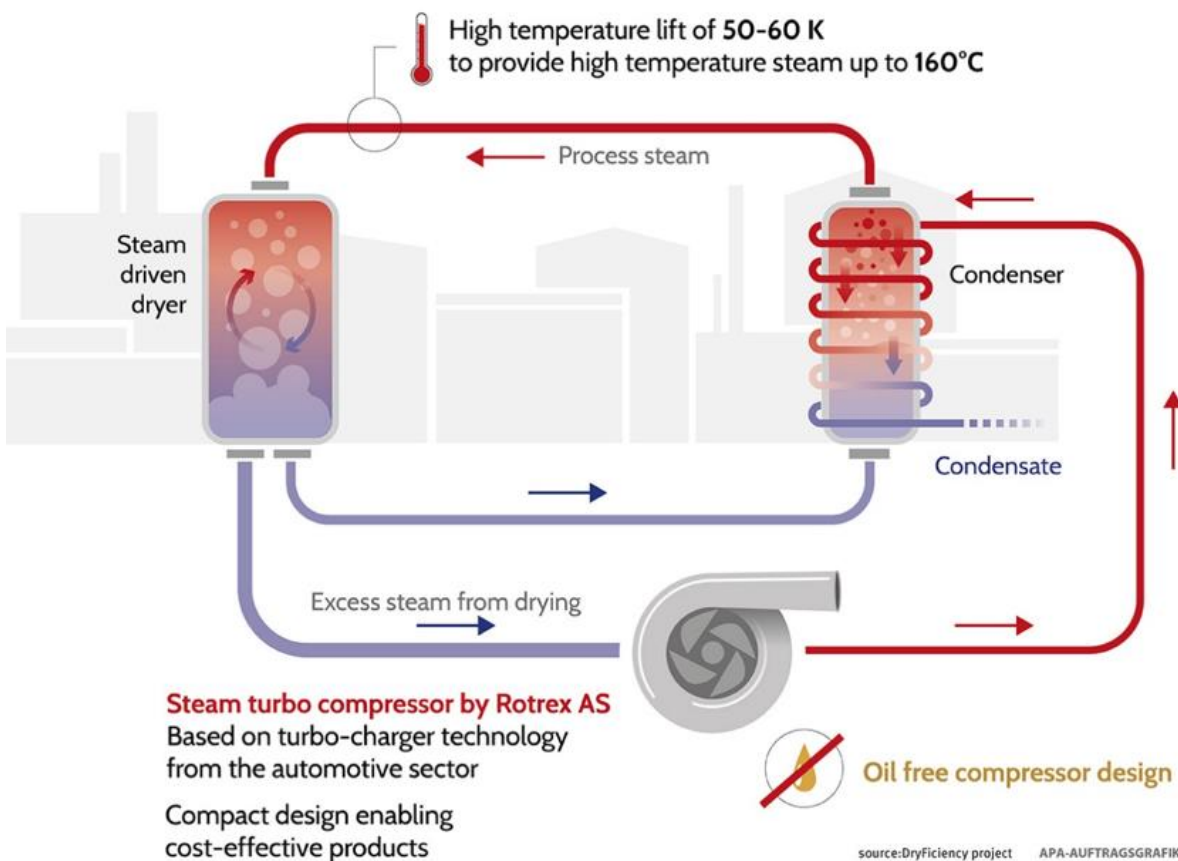

Figure 29: Open loop heat pump and their innovations

In the following chapter, the two open loop heat pump demonstrator is described providing also information on its integration in the sludge drying process.

3.1.1 Integration layout for the sludge drying process

The open loop MVR heat pump for the sludge drier is installed on two batch dryers of Scanship Holding ASA in Drammen/Norway. The installed MVR system is large enough to connect the two dryers in parallel to the open loop heat pump.

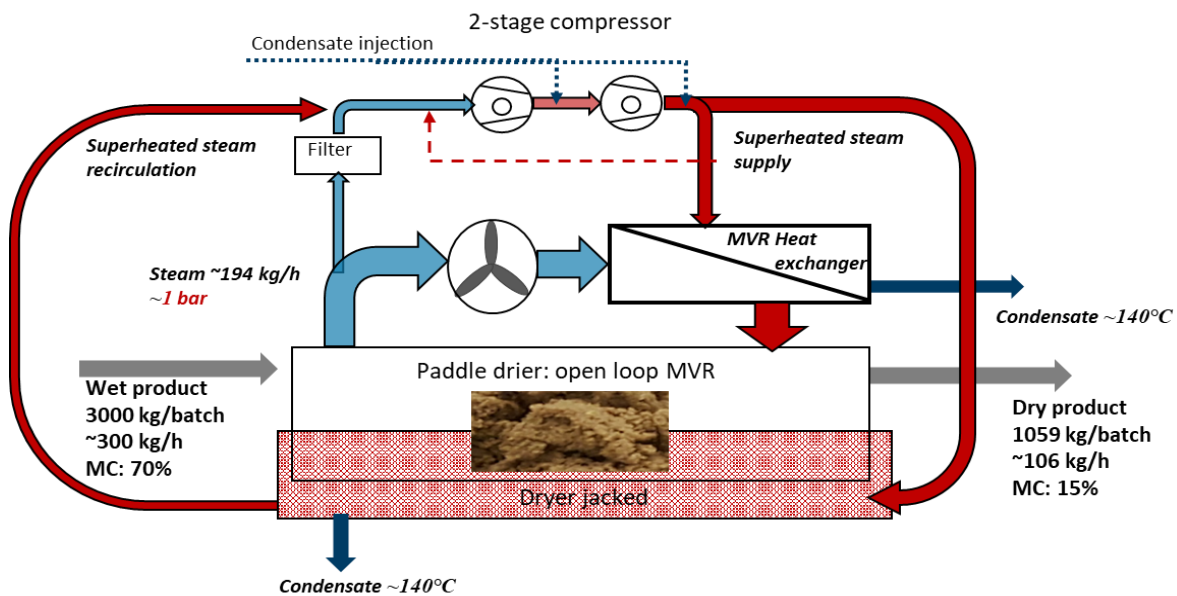

Figure 30: Schematic integration layout of MVR-dryer for sludge drying

The dryer of the demonstration unit has a thermal capacity of approximately 200 kW and will be operated close to the atmospheric pressure of 0.8-1 bar. Operation at 1 bar (=atmospheric pressure) will be more beneficial with respect to achievable temperature lift of the open loop heat pump because of the higher temperatures in the system.

A steam filter is installed at the inlet of the open loop heat pump in order to ensure that no particles will enter the compressors. The compressed steam will then be condensed in the MVR heat exchanger as well as the dryer jacket. The installation of the MVR heat exchanger is necessary in order to get enough surface area for the heat transfer, since the heat exchanger area of the drier jacket is too small. The MVR heat exchanger is a plate heat exchanger and the MVR-steam is condensed inside the plates. This allows to open the heat exchanger and clean the outside wall of the plates during maintenance, since a certain degree of fouling is expected from the process steam.

Two dryers will be connected to the open loop heat pump, which is placed side-by-side with the two dryers.

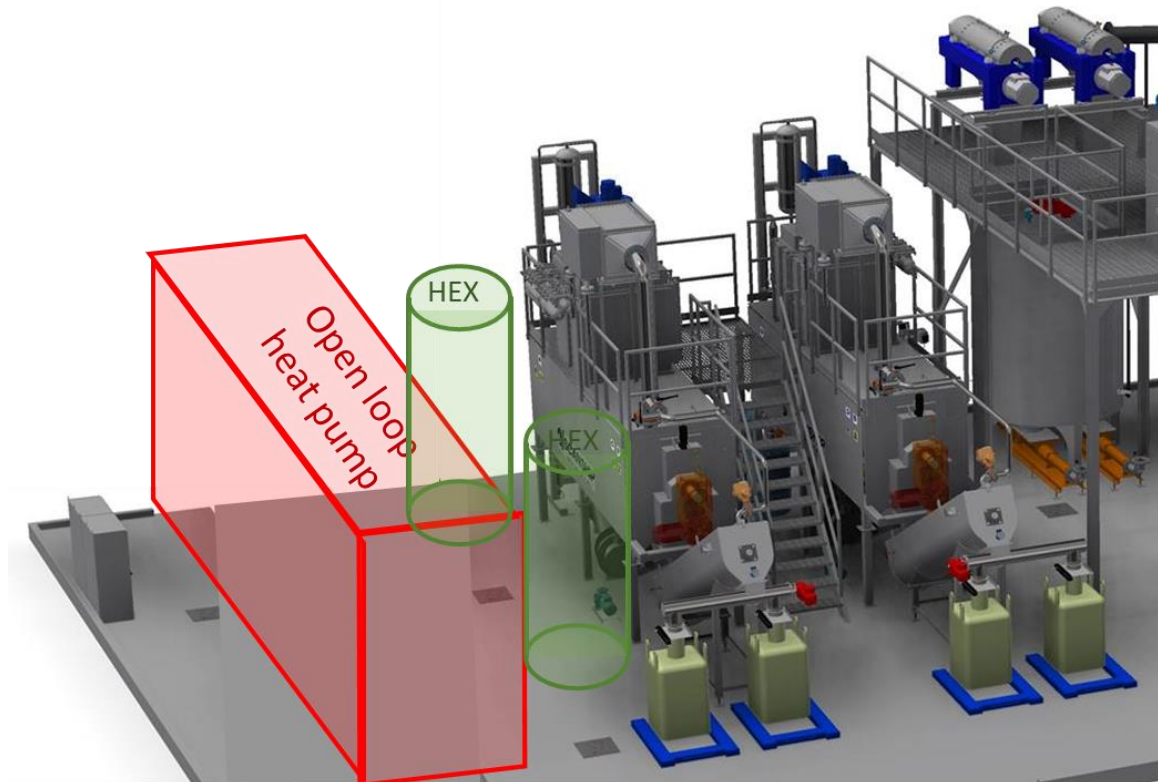

Figure 31: Placement of the open loop heat pump at the Scanship demosite.

For the full scale it is possible to operate two driers to one open loop heat pump. The dryer of the demonstration unit will have a reduced size compare to the full-scale system and will also allow for flexible product testing under varying drying conditions, products and capacities.

An additional steam generator is installed for redundancy reasons and in in order to compensate for capacity variations as well as for the start-up procedure.

3.1.2 Integration infrastructure for the open loop heat pump

1) Power supply

The open loop heat pump is controlled a standard AC30 Parker inverter (see Figure 32) for each compressor. For each compressor one inverter is needed and both inverters are integrated in the control system of plant operation. The inverter enables a controlled start-up procedure up to a certain motor speed in order to pre-heat the open loop system as well as the driers. Once the systems reach a stable operational condition in steam the inverters are ramping up the compressors to the full speed.

The electrical power required to operate the open loop heat pump is approximately 80 kW in the first stage and 60 kW in the second stage (including mechanical losses in the gearbox and motor) and will vary according to the isentropic efficiency of the compressors. It was therefore necessary to install a large enough power supply (see Figure 33) for each inverter. Since the plant commonly is operated by fossil fuel it was required to install new power cabinets; this is necessary infrastructure for all large scale industrial heat pumps and needs to be communicated to the plant operator.

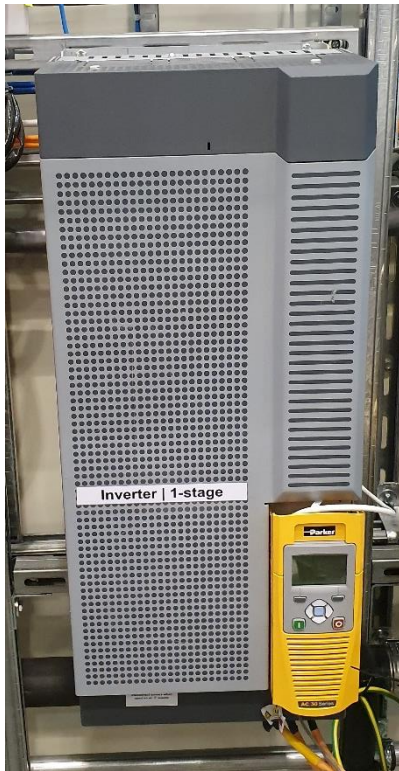

Figure 32: Inverter for power supply to the compressors: stage one with 135 kW (left) and stage two with 75 kW (right)



Figure 33: Power supply for the open loop heat pump system (left: for stage one; right: for stage two).

2) MVR heat exchanger

The MVR heat exchanger links the open loop system to the drier and can be seen as a part of the drier or the heat pump. It was discussed to connect both driers by one joint heat exchanger. In the end it was decided to install two smaller heat exchangers for each drier so that (also under the aspect of redundancy) each drier can be operated individually.

The heat exchangers are larger than common steam condensers, since the volume flow of the process steam is significantly higher compare to the volume flow of MVR-steam. Each MVR heat exchanger is a plate heat exchanger and the MVR-steam is condensed inside the plates. This allows to open the heat exchanger and clean the outside wall of the plates during maintenance, since a certain degree of fouling is expected from the process steam.

The jacket of the drier (see Figure 34) operates as additional heat exchanger and was originally used to supply the required drying energy by a thermal oil when the system was operated as air dryer.



Figure 34: The jacket of the SHS-drier operates as MVR heat exchanger for the open loop heat pump. Picture is taken before mounting the SHS-drier.

3.1.3 Open Loop Heat Pump Demonstrator

1) Compressors

The compressors for the open loop heat pump can be seen in Figure 35 and are turbo compressors of the model EA42 with a custom dedicated impeller design for stage 1 and stage 2. The gearbox is cooled internally and the cooling water from the DC motor can be used to cool the gearbox. This is a significant improvement from the former EC38 units which required external oil cooling.

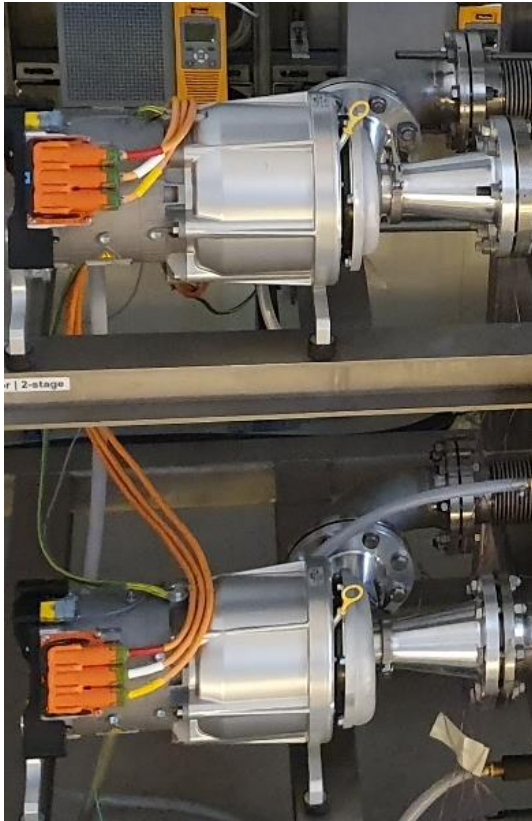

Figure 35: The two EA42 turbo-compressors from Rotrex mounted in the open loop heat pump (left). The cooling system requires only a water connection (top right) and not an external oil cooling system like the EC38 model (down right).

Further improvement includes that the inlet and outlet connections from the compressor to the system can be adjusted so that standard industry piping and screw connections can be used. Figure 36 shows the connection pipe work of the EA42 and EC38 compressor, respectively.



Figure 36: Flexible adjustment of the inlet and outlet of the EA42 unit enables standard connections (left), while the EC38 model needs a specially welded connection arrangement (right).

2) De-superheater

The open loop heat pump requires a significant amount of de-superheating since the pressure ratio per compression stage is high. De-superheating by direct water injection will require a pipe length longer than 14 meters. Due to the space requirements onsite it was not possible to install such a "long" system.

A bed of metal packings was installed as de-superheater between stage 1 and stage 2 as well as after the second stage in order to de-superheat the MVR steam. The water is then injected at the top of the packed bed and the packings provide enough surface area as well as duration time to evaporate the required amount of water for de-superheating. Figure 37 shows the top and bottom of the packed bed for de-superheating.



Figure 37: Bed of metal packings for improved and more compact de-superheating between compressor stage 1 and compressor stage 2.

4 CONCLUSIONS

4.1 Closed Loop

The basic and detailed engineering, as well as construction and integration, work has been finalized. The use of the container solutions for the two heat pumps has proven advantageous, as it allowed the pre-manufacturing of the heat pumps at the subcontractor's premises. Continuous coordination and management of the interface between heat pump prototype and industrial drying process proved to be an important factor for successful integration.

4.2 Open Loop

The design and engineering of the open loop heat pump has been finalized and the system is ordered. The open loop heat pump will recover the drying energy of two batch driers which are operated in parallel. The use of a more compact de-superheating concept based on metal packings has been advantageous. The design of the EA42 turbo compressor prototypes allow for a simplified physical installation of the units. The system will be mainly controlled by the two inverters which will be used to ramp the system.