

**Grant Agreement No.: 723576**

## **DryFiciency**

**Waste Heat Recovery in Industrial Drying Processes**

**H2020-EE-2016-2017-PPP**

**Valorisation of waste heat in industrial systems (SPIRE PPP)**

# **Report on the validation of the energy savings for each demo site**

**D5.2**

**This is a Deliverable of WP 5.**

**Deliverable Leader: Veronika Wilk (AIT)**

**Authors: Veronika Wilk, Bernd Windholz, Annemarie Schneeberger (AIT)**

Project co-funded by the European Commission within H2020 Programme

## INDEX

<b>Executive Summary</b> .....	<b>4</b>
<b>1 Introduction</b> .....	<b>5</b>
<b>2 Closed loop heat pump</b> .....	<b>7</b>
2.1 Methodology.....	7
2.1.1 Data from heat pump operation .....	7
2.1.2 Environmental and economic impact.....	8
2.2 Process description .....	10
2.2.1 Heat pump assisted drying of starch at Agrana.....	10
2.2.2 Heat pump assisted drying of bricks at Wienerberger .....	10
2.3 Heat pump characteristics .....	11
2.3.1 Coefficient of performance .....	11
2.3.2 Heating capacity and electricity consumption .....	13
2.4 Environmental and economic impact .....	14
<b>3 Open loop heat pump</b> .....	<b>17</b>
<b>4 Conclusion</b> .....	<b>21</b>
4.1 Closed loop heat pumps.....	21
4.2 Open loop heat pump.....	21

**Statement of originality:** This deliverable contains original unpublished work except where clearly indicated otherwise. Acknowledgement of previously published material and of the work of others has been made through **appropriate** citation, quotation or both.

NOTES: For comments / suggestions / contributions to this document, contact: Coordinator of DryFiciency project at [Veronika.Wilk@ait.ac.at](mailto:Veronika.Wilk@ait.ac.at). For more information on the project DryFiciency: [www.dryficiency.eu](http://www.dryficiency.eu)

## List of abbreviations

AGA	Agrana
COP	Coefficient of Performance
EEHP	Energy Efficiency of Heat Pump
KPI	Key Performance Indicator
MVR	Mechanical Vapor Recompression
PCS	Process Control System
PES	Primary Energy Savings
SEC	Specific Energy Consumption
SHS	Superheated steam
WBG	Wienerberger

## EXECUTIVE SUMMARY

Deliverable D5.2 *Report on the validation of the energy savings* reports on selected results of key performance indicators achieved by the two closed loop heat pump demonstrators, with one DryF™ heat pump installed for green brick drying at a plant of [Wienerberger AG](#) in Uttendorf (AT) and one integrated for starch drying at a plant of [Agrana Stärke GmbH](#) in Pischelsdorf (AT). Specifically, information is provided on the reductions of energy consumption and carbon emission savings achieved as well as the heat pump installations' impact on the companies' energy bills. On the other hand, it contains the energy savings from the open loop heat pump testing at the site of Lindum conducted by [SINTEF](#) and [Scanship AS](#).

The heat pump demonstrators and their integration infrastructures are described in detail in [D4.3 Integrated Heat Pump System](#).

More information on the boundary conditions, the design and configuration of the novel heat pump prototypes, and the research and development work undertaken on component and heat pump unit level, are provided in [D4.5 Interim report on the heat pump technologies developed](#). Work conducted and results achieved during integration, commissioning and demonstration of the heat pump systems developed and demonstrated for the first time in an industrial setting are included in [D5.4 Final report on the heat pump technologies developed](#)

Information on the training and knowledge sharing formats, tools and materials elaborated to broadly spread results, lessons learned, and experiences gained from the projects' development and demonstration activities is published in [D6.9 Guidelines on Lessons Learned and Training materials](#).

# 1 INTRODUCTION

Industrial drying and dehydration processes require vast amounts of energy. Estimates show that in developed countries, 12 to 25% of the industrial energy consumption is attributable to industrial drying. Currently, most of this energy is derived from fossil fuel use, with little-to-no utilization of waste heat streams. Hence, there is great potential for more efficient and environmentally-friendly technologies within industrial drying processes.

Industrial heat pumps are an efficient heat recovery technology still in an early phase of market diffusion gaining increasingly attention from both policy makers and industrial end-users. Stringent environmental legislation (“European Green Deal”), a more favorable gas and electricity price ratio as well as rising prices for carbon dioxide emission certificates are the driving forces behind this development.

In the DryFiciency project, **three novel high temperature heat pump (HTHP) systems** were developed and **demonstrated first-time in industrial environment** with supply temperatures of **up to 160°C** thereby utilizing waste heat streams from **three drying processes** in **three industrial sectors**.

**Food industry:** A novel closed loop heat pump technology was implemented for **drying of starch** from potato, wheat, and corn at a production site of Agrana Stärke GmbH ([www.agrana.com](http://www.agrana.com)) in Pischelsdorf, Austria.



**Ceramic sector:** An innovative closed loop heat pump was implemented for **green brick drying** by Wienerberger AG ([www.wienerberger.com](http://www.wienerberger.com)), the largest brick producer worldwide, in a brick production plant in Uttendorf, Austria.



**Waste management industry:** An improved MVR drying technology for **sludge drying** was installed together with an innovative open loop heat pump in a land-based waste management system in Drammen, Norway.



The three advanced high temperature heat pump systems comprise of two closed loop heat pump systems based on the novel refrigerant Opteon™ MZ (R-1336mzz(Z)) and one open loop heat pump system using water (R-718) as refrigerant.



**Two advanced compressor technologies**, modified screw compressors by Bitzer Kühlmaschinenbau GmbH ([www.bitzer.de](http://www.bitzer.de)) and novel piston compressors by Viking Heat Engines (now Heaten AS [www.heaten.no](http://www.heaten.no)) enable discharge temperatures of up to 160°C. Two screw compressors are integrated in the heat pump application at Agrana for starch drying; the one for brick drying at Wienerberger uses eight piston compressors.





A **unique synthetic lubricant** for high temperature applications, which was developed by FUCHS ([www.fuchs.com](http://www.fuchs.com)) for both compressors and which is sufficiently viscous and chemically stable with the refrigerant selected (Opteon™ MZ from Chemours) at elevated temperature levels.



**Opteon™ MZ** from Chemours ([www.chemours.com](http://www.chemours.com)), a synthetic refrigerant based on HFO (hydrofluoro-olefin), was developed, prior to the project, for high temperature applications with heat supply temperatures of up to 160°C. It has a low GWP (Global Warming Potential) of 2 and demonstrates a number of favourable characteristics, such as non-flammability and non-toxicity. It is also not subject to the EU legislation to control F-gases (so called F-gas regulation).



The **design of the closed loop refrigeration cycle** was developed by AIT ([www.ait.ac.at](http://www.ait.ac.at)) based on numerical simulations. AIT was also responsible for **optimized construction, integration, and operation** of the two heat pump prototypes, including **scientific monitoring** and **evaluation** of the heat pumps achievements on unit and system level.

The **main innovations** of the **open loop heat pump system**, commonly referred to as MVR (Mechanical Vapour Re-compression), includes:



**Advanced, low-cost, oil-free turbo-compressor technology** from ROTREX AS ([www.rotrex.com](http://www.rotrex.com)), which originates from the automotive sector, has been further developed to reach condensation temperatures up to 155°C.



**Novel, highly efficient, MVR dryer technology** developed by Scanship ([www.scanship.no](http://www.scanship.no)), which has achieved efficiency/capacity gains of more than 75%, while reducing energy consumption by 70%.



The **design of the MVR system** was elaborated and implemented by EPCON ([www.epcon.no](http://www.epcon.no)) and SINTEF ([www.sintef.no](http://www.sintef.no)). SINTEF and EPCON were also responsible for **optimized construction, integration, and operation** of the heat pump prototype. Besides, SINTEF was in charge of **scientific monitoring & evaluation** of the HP's achievements on unit and system level.



## 2 CLOSED LOOP HEAT PUMPS

### 2.1 Methodology

#### 2.1.1 Data from heat pump operation

Figure 1 depicts the process chain from data logging to visualization and reporting, using the Agrana demo case as example. Data from the heat pump and from the process control system of Agrana is transferred online to AIT.

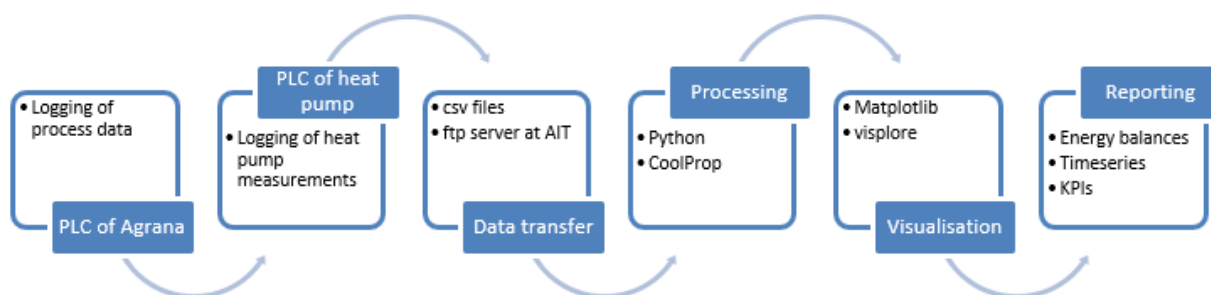

Figure 1: From data logging to visualization and reporting at demo case Agrana

The data processing, from the collection to visualisation and reporting, is done with the help of python<sup>1</sup> scripts. From the ftp server a script collects the csv data files and transforms the data from string to numerical formats. Missing timestamps are detected automatically and marked for further analysis. Fluid properties like density and specific enthalpy are calculated from measurement data using the open source thermophysical property library CoolProp<sup>2,3</sup>.

For time-independent characteristics of the heat pump to be analysed, such as the COP, heating capacity and electricity consumption at certain operational conditions, a python script was developed that automatically filters the interesting timeseries of heat pump data on a defined grid of chosen input variables, such as source and sink temperatures and compressor frequencies, each having a certain discretization (5 K for temperatures, 10 Hz for frequencies), resulting in about 2 million combinations for the Agrana heat pump. The values are resampled to their 90 seconds mean values and only normal operation of the heat pump is considered (i. e. no start-up). For a timestamp to be used, the input variables have to fulfil a stability criterium, i. e. the absolute difference of their values has to be below certain limits compared to the timestamp before. For the resulting timestamps the statistics of the interesting variables are stored (number of time stamps, mean value, standard deviation, minimum, maximum, quartiles). For the evaluation only operation conditions are used which have been monitored for more than 10 hours. This allows for a statistical approach for data analysis.

<sup>1</sup> [www.python.org](http://www.python.org) Python is a programming language that let you work quickly and integrate systems more effectively.

<sup>2</sup> Bell, Ian H. and Wronski, Jorrit and Quoilin, Sylvain and Lemort, Vincent: Pure and Pseudo-pure Fluid Thermophysical Property Evaluation and the Open-Source Thermophysical Property Library CoolProp. Industrial & Engineering Chemistry Research, vol. 53, number 6, pages 2498-2508, year 2014, URL <http://pubs.acs.org/doi/abs/10.1021/ie4033999>, eprint <http://pubs.acs.org/doi/pdf/10.1021/ie4033999>

<sup>3</sup> [www.coolprop.org](http://www.coolprop.org)

### 2.1.2 Environmental and economic impact

For the calculation of impact, the reference process heat supply technology is used for comparison, a natural gas burner. With a heating capacity of up to 400 kW, the DryEfficiency heat pump demonstrators only supply part of the heat required for brick or starch drying. Therefore, the impact assessment refers to the heat pump only, not to the complete production process. The heat pump is compared to a natural gas burner providing the same amount of process heat. Due to the integration of the heat pump, natural gas consumption is replaced by a considerably small amount of electricity.

Four parameters are assessed: end energy, primary energy, CO<sub>2</sub> emissions and energy costs. Therefore, relative reductions of the process with and without heat pump are calculated using Eq. 1-4.

#### End energy reduction $\Delta E$

The relative reduction of end energy is calculated according to Eq. 1.  $E_{ref}$  is the amount of end energy needed in the reference system, which is a natural gas burner providing the same amount of heat as the heat pump. The gas burner has an efficiency  $\eta_{ref}$  of 90%. The end energy consumption of the heat pump is electricity,  $E_{HP}$ . It is calculated using measured values (statistical approach as described above).

$$\Delta E = \frac{E_{ref} - E_{HP}}{E_{ref}} = 1 - \frac{\eta_{ref}}{COP}$$

Eq.1

#### Primary energy consumption $\Delta PE$

The reduction in primary energy consumption is calculated using Eq. 2. It compares primary energy consumption from natural gas (reference system, natural gas burner) to electricity (heat pump). The primary energy factors  $f_{PE}$  also include the production of the energy carrier itself, such as extraction, processing, storage, transport, conversion, transmission and distribution to provide end energy. Primary energy consumption for electricity is predominantly influenced by the energy carriers used for electricity generation. For this comparison, factors based on current European averages are used. In 2019, the European Parliament defined the primary energy factor to be used for the calculation of the energy efficiency targets to 2.1 kWh/kWh for electricity<sup>4</sup>, for natural gas, the factor amounts to 1.1<sup>5</sup>.

$$\Delta PE = \frac{PE_{ref} - PE_{HP}}{PE_{ref}} = PEF_g - \frac{\eta_{ref} PEF_{el}}{COP}$$

Eq. 2

#### CO<sub>2</sub> emission reduction $\Delta CO_2$

Similar to the primary energy consumption, the reduction in CO<sub>2</sub> emissions is calculated using Eq. 3. The CO<sub>2</sub> emissions are calculated as CO<sub>2</sub> equivalent also considering other greenhouse gases such as methane or nitrous oxide. The emission factors  $f_{CO_2}$  also include the production of the energy carrier itself, such as extraction, processing, storage, transport, conversion, transmission, and

---

<sup>4</sup> European Parliament, 2018c, Position of the European Parliament, 13 November 2018, first reading 2016/0376(COD) adopted at first reading on 13 November 2018 with a view to the adoption of Directive (EU) 2018/... of the European Parliament and of the Council amending Directive 2012/27/EU on energy efficiency (EP-PE\_TC1-COD(2016)0376)

<sup>5</sup> EN ISO 52000. Energy performance of buildings - Overarching EPB assessment - Part 1: General framework and procedures (ISO 52000-1:2017), Edition: 2018-02-01



distribution to provide end energy. The CO<sub>2</sub> emission factor is the ratio of CO<sub>2</sub> equivalent emissions and end energy. The CO<sub>2</sub> emissions from electricity are predominantly influenced by the energy carriers used for electricity generation. For this comparison, Austrian factors according to Table 1 were applied. Currently, the use of electrical energy in Austria leads to 258 g CO<sub>2</sub>eq /kWh, use of natural gas accounts for 271 g/kWh.<sup>6</sup> With a share of 75% in Austria's electricity generation in 2018, renewable energy sources, mostly hydropower<sup>7</sup>, are already broadly used.<sup>8</sup>

$$\Delta CO_2 = \frac{CO_{2,ref} - CO_{2,HP}}{CO_{2,ref}} = f_{CO_2,g} - \frac{\eta_{ref} f_{CO_2,el}}{COP}$$

Eq. 2

### Energy cost reduction $\Delta OPEX$ :

In analogy to the other parameters, Eq. 3 is applied for energy cost reductions. Energy costs are based on mean values for the Austrian industry from the 2<sup>nd</sup> half year of 2020 are used, which are 9.86 ct/kWh for electricity for non-household customers with a purchase of 70,000 MWh/a to 150,000 MWh/a<sup>9</sup> and 4.069 ct/kWh for natural gas for non-household customers with a purchase of 2,778 MWh/a to 5,595 MWh/a<sup>10</sup>.

$$\Delta OPEX = \frac{OPEX_{ref} - OPEX_{HP}}{OPEX_{ref}} = c_g - \frac{\eta_{ref} c_{el}}{COP}$$

Eq. 3

Table 1: Factors for the calculation of emissions, primary energy, and costs

	Unit	Electricity (el)	Natural gas (ref)
Operation costs (c)	€/MWh	98.6	40.69
CO <sub>2</sub> emission factors (f <sub>co2</sub> )	g CO <sub>2</sub> eq/kWh	258	271
Primary energy factors (PEF)	kWh/kWh	2.1	1.1

<sup>6</sup> Umweltbundesamt, Calculation of green house gas emissions for different energy carriers in Austria, updated in January 2020, <https://secure.umweltbundesamt.at/co2mon/co2mon.html>, accessed on 13.5.2021

<sup>7</sup> 60% of gross electricity generation

<sup>8</sup> E-Control 2019, Statistikbroschüre, [Link](#), Accessed on 02.05.2020

<sup>9</sup> eControl, electricity prices, [Link](#), Accessed on 13.5.2021

<sup>10</sup> eControl, natural gas prices, [Link](#), Accessed on 13.5.2021

## 2.2 Process description

### 2.2.1 Heat pump assisted drying of starch at Agrana

The starch drying process concerned is a continuous process with an integrated closed loop heat pump system, as seen in Figure 2. The drying agent (air) is preheated by a water-to-air heat exchanger from a heat recovery cycle with water as heat transfer fluid. After this initial preheating, the water also serves as the source for the evaporator of the heat pump system. The inlet temperature is then  $\approx 70^{\circ}\text{C}$ . At the condenser side, high temperature heat is released to the drying agent via an intermediate water circuit and a water-to-air heat exchanger. The heat supply temperature of the heat pump is up to  $160^{\circ}\text{C}$  and is measured at the outlet of the condenser in the intermediate water circuit. As a result of these consecutive preheating steps of the drying agent, less energy is needed in the steam generator to reach a desired temperature level of  $\approx 160^{\circ}\text{C}$  at the inlet of the flow stream dryer.

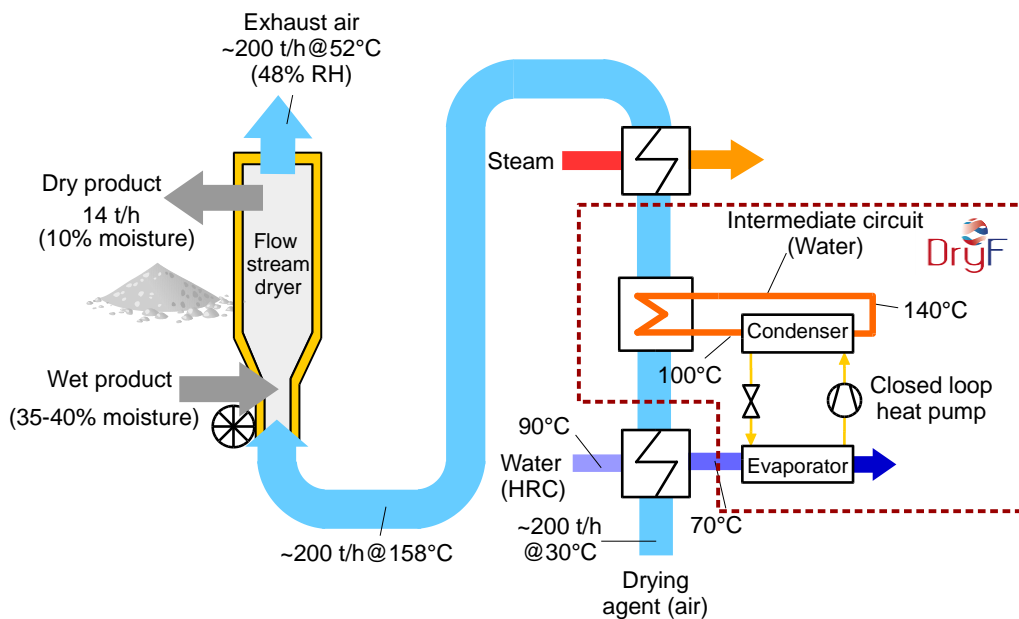

Figure 2: Schematic diagram of the heat-pump assisted starch dryer

### 2.2.2 Heat pump assisted drying of bricks at Wienerberger

The brick drying process in DryFiciency is a continuous tunnel dryer that is illustrated in Figure 3. Air is used as drying agent that flows counter-currently to the bricks. Bricks enter the dryer with 28% moisture and are dried to 2%. Drying air in the tunnel is heated by internal heat exchanger surfaces, which are supplied with water with  $90^{\circ}\text{C}$  by a heat recovery cycle. The heat pump also uses the heat recovery cycle as the heat source. The evaporator is inserted before the heat exchangers. The heat pump provides hot air via an intermediate circuit, heat supply temperatures up to  $160^{\circ}\text{C}$  can be reached there. The hot air is fed into the outlet zone of the tunnel dryer, where the highest temperatures are required. The heat pump acts as a booster for the heat recovery cycle.

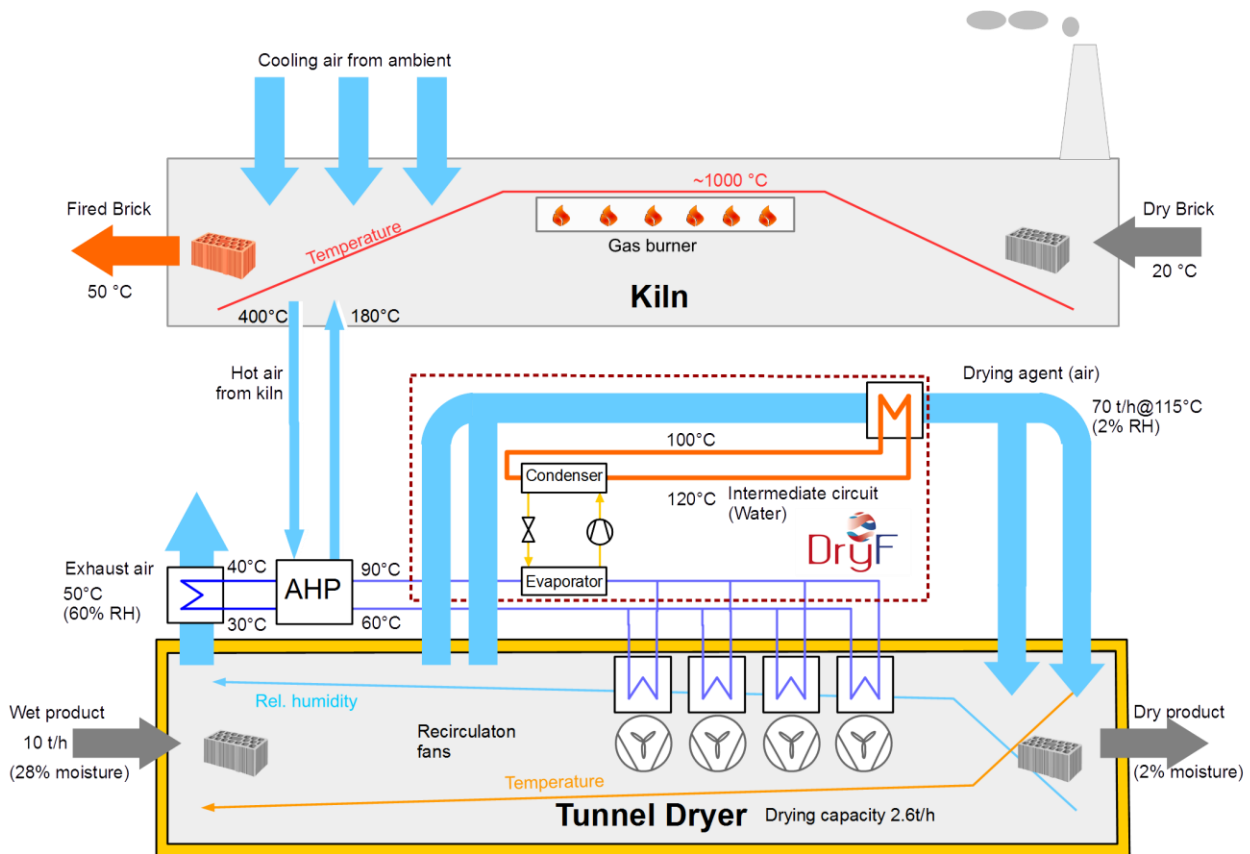

Figure 3: Schematic diagram of the heat pump integration at the Wienerberger tunnel dryer.

## 2.3 Heat pump characteristics

### 2.3.1 Coefficient of performance

Figure 4 and Figure 5 provide an overview of the heat pump (COP) efficiency as a function of the temperature lift, which is the temperature difference between heat source outlet and heat sink outlet. The COP is the ratio of heat supplied to the process and electricity consumed by the heat pump. This analysis is based on the statistical approach considering all data collected during demonstration explained in 2.1.1. Each data point shown in the diagram represents at least 10 h of stationary operation with constant temperatures and compressor speed. The error bars illustrated for each data point show how much variation was found in operation data that is presented as a single data point. In the diagram, the COP for an ideal heat pump with a second law efficiency of 50% and a heat supply temperature of 120°C is also included.

The COP of the Agrana demonstrator ranges from 4.3 at 107°C (heat sink outlet) and 68°C (heat source outlet) to 2.7 at 153°C (heat sink outlet) and 73°C (heat source outlet). The variations of COP and temperature lift were on average 3%.

For the Wienerberger demonstrator, the COP ranges from 5.0 at 120°C (heat sink outlet) and 84°C (heat source outlet) to 2.2 at 160°C (heat sink outlet) and 89°C (heat source outlet) demonstrator. The variations for the COP are on average 3%, the variations of the temperature lift are slightly higher with ca. 4%.

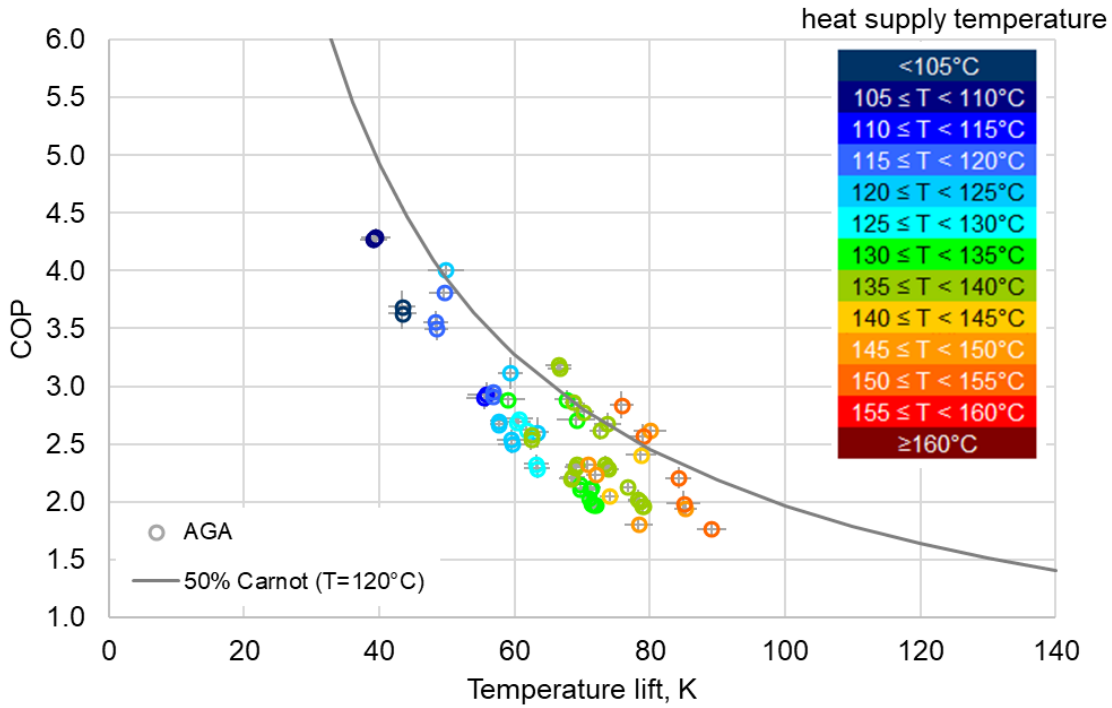

Figure 4: Performance data of the heat pump demonstrators with ranges of variation at Agrana

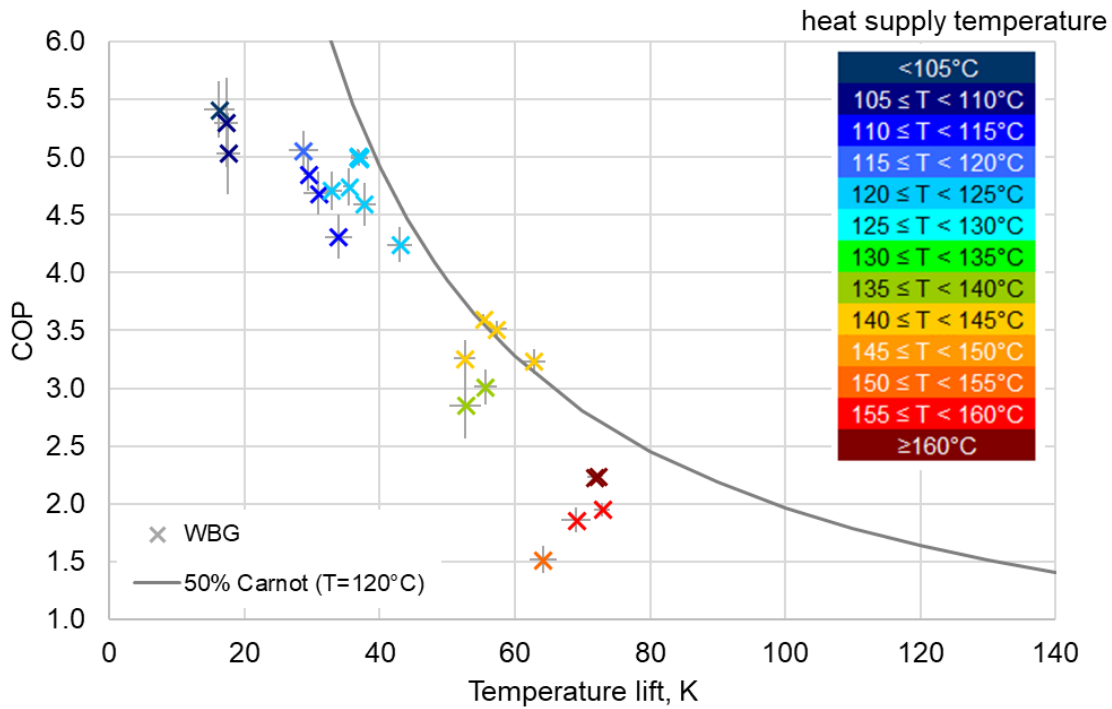

Figure 5: Performance data of the heat pump demonstrators with ranges of variation at Wienerberger

### 2.3.2 Heating capacity and electricity consumption

Figure 6 illustrates the range of heating capacities and electricity consumption of the heat pump for the different operation points with at least 10 h stationary operation for the Agrana demonstrator. The yellow area indicates the design point. At a heat supply temperature of 138°C and a heat source outlet temperature of 71°C, the heating capacity was 374 kW and the electricity consumption 117 kW. The COP amounts to 3.2. In the design point, the maximum heating capacity was achieved. According to Figure 4, higher COP were reached when operating at lower temperature lifts. As evident, also part load conditions were tested, e.g., operation of one cycle only or operation at reduced compressor speed.

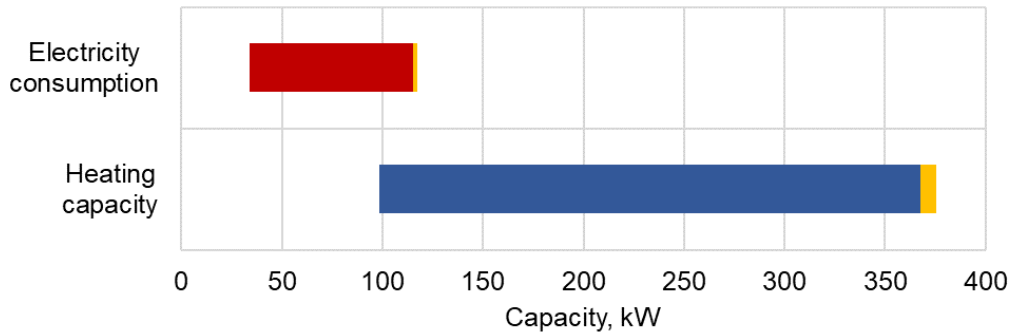

Figure 6: Heating capacity and electricity consumption, Agrana demonstrator

The design point of the Wienerberger demonstrator (Figure 7) was at a heat supply temperature of 120°C. The heating capacity amounted to 297 kW; the electricity consumption was 59 kW. The COP was 5.0 for a temperature lift of 37 K. Here, also the maximum heating capacity was supplied. Compared to the Agrana heat pump, the maximum heating capacity was lower by about 20%. Part load operation was also tested, reducing the heating capacity to a third.

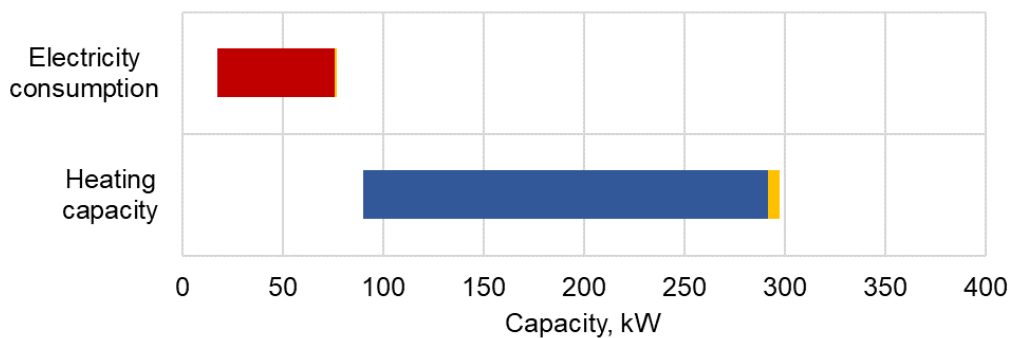

Figure 7: Heating capacity and electricity consumption, Wienerberger demonstrator

## 2.4 Environmental and economic impact

Table 2 summarizes the results of the DryFiciency heat pump at Agrana in comparison to a natural gas burner for operation in the design point (138°C heat supply temperature); Table 3 for the heat pump at Wienerberger (120°C heat supply temperature). Reductions are presented both in absolute values and as percentage. Figure 8, Figure 9, Figure 10 and Figure 11 give an overview on the operation of the heat pumps with the design point illustrated in yellow.

*Table 2: Environmental and economic impact for operation of the Agrana heat pump at 138°C*

	Gas burner with equal heating capacity	DryFiciency Heat Pump	Reduction
End energy, MWh/a	3326	938	2388 72%
Primary energy, MWh/a	3659	1969	1689 46%
CO <sub>2</sub> emissions, t/a	901	242	659 73%
Energy costs, €/a	135334	92453	42881 32%

*Table 3: Environmental and economic impact for operation of the Wienerberger heat pump at 120°C*

	Gas burner with equal heating capacity	DryFiciency Heat Pump	Reduction
End energy, MWh/a	2638	475	2163 82%
Primary energy, MWh/a	2902	998	1904 66%
CO <sub>2</sub> emissions, t/a	715	123	592 83%
Energy costs, €/a	107341	46842	60499 56%

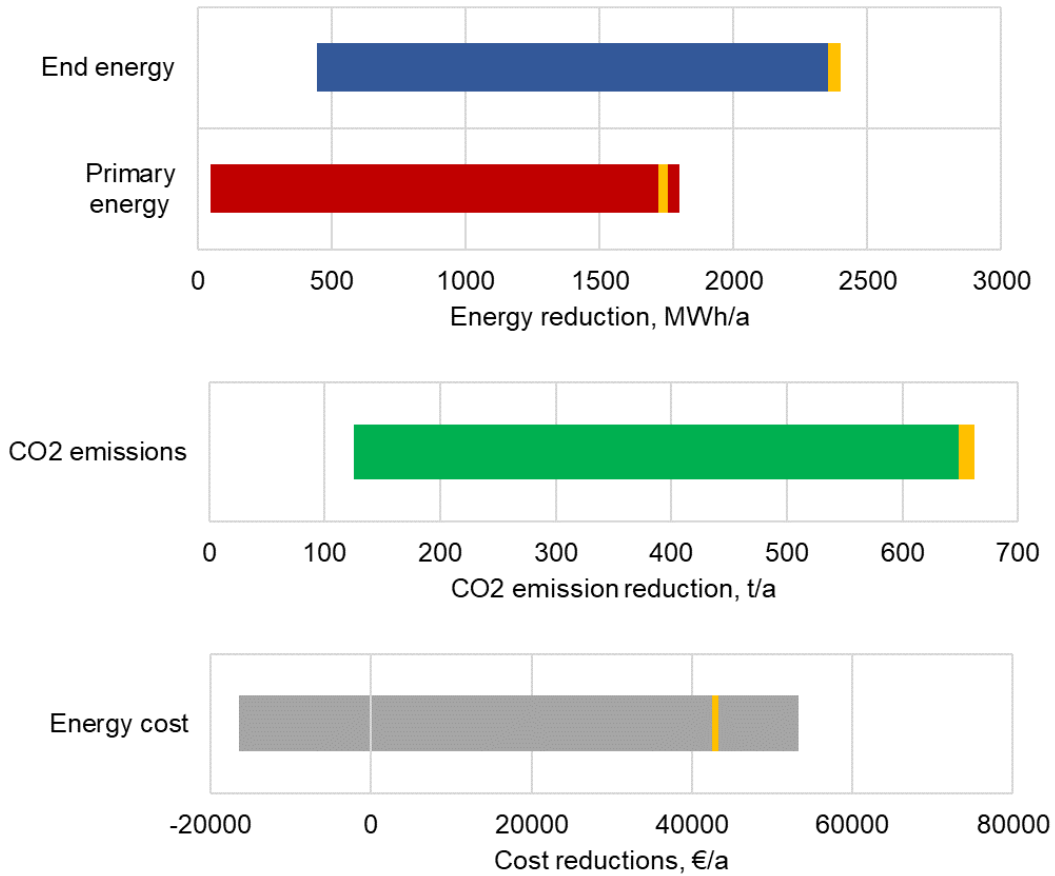

Figure 8: Environmental and economic impact, Agrana demonstrator compared to natural gas burner

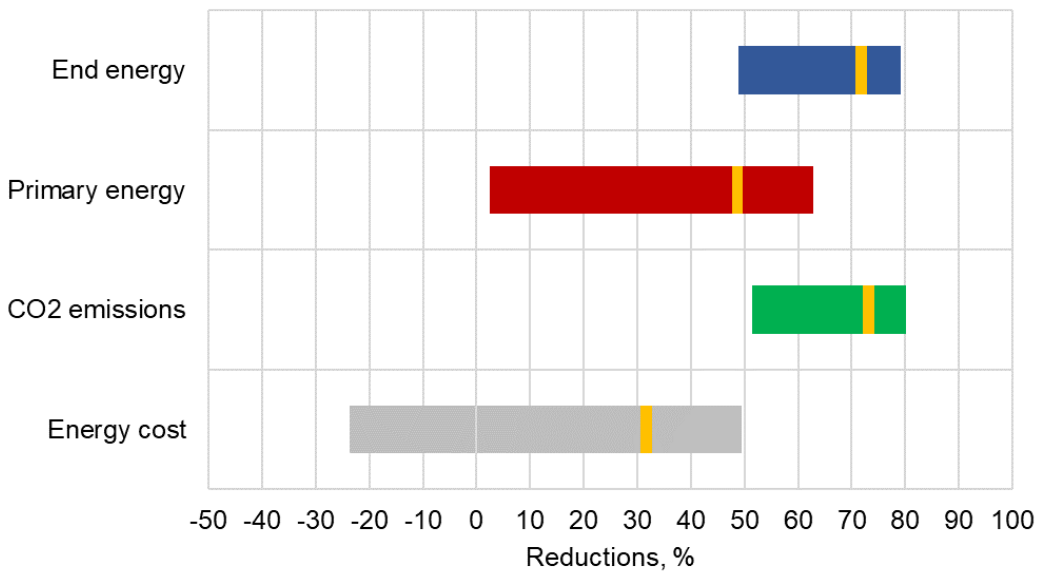

Figure 9: Environmental and economic impact as relative reductions, Agrana demonstrator compared to natural gas burner

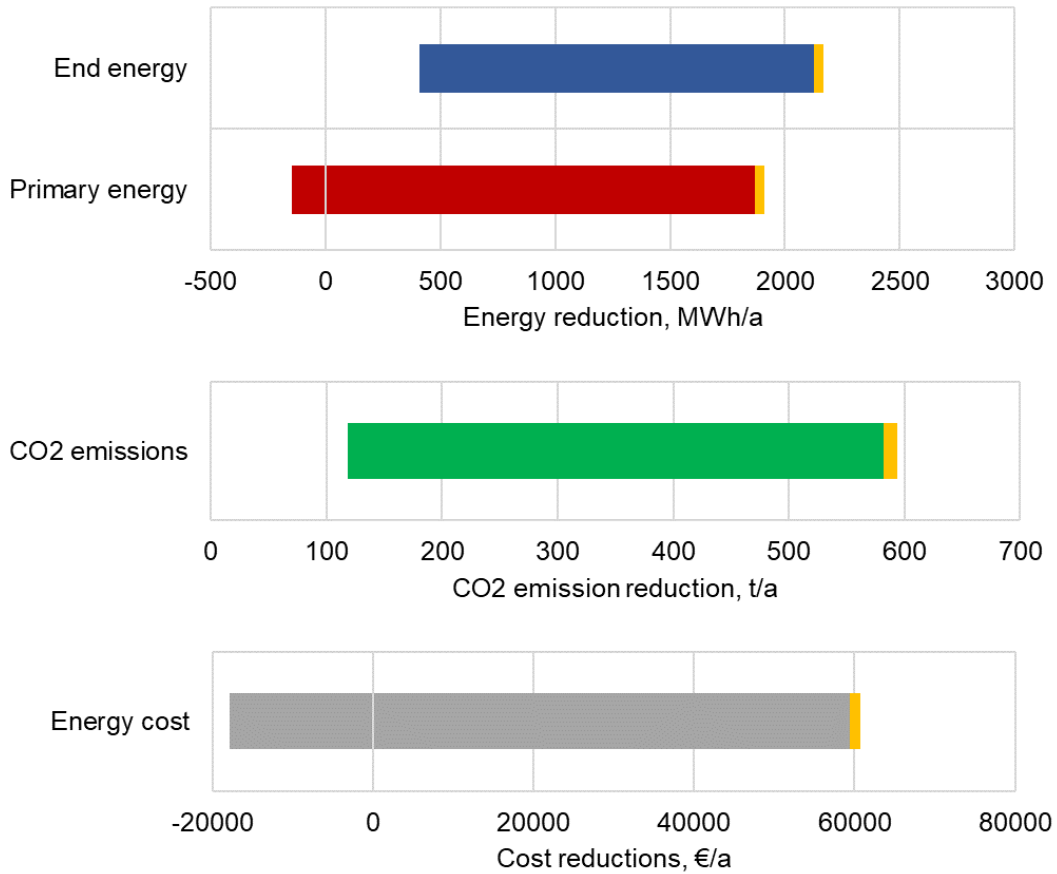

Figure 10: Environmental and economic impact, Wienerberger demonstrator compared to natural gas burner

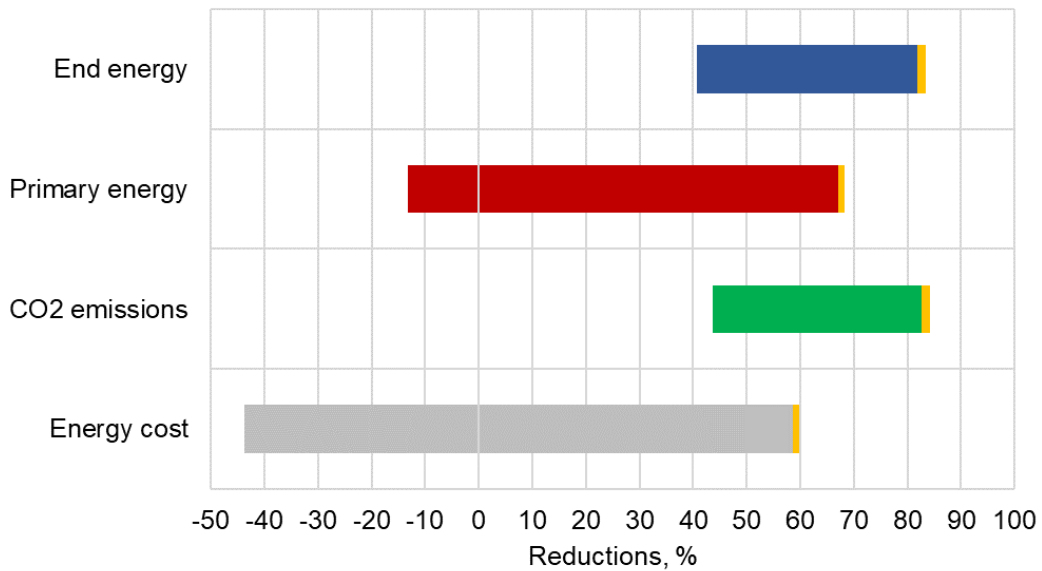

Figure 11: Environmental and economic impact as relative reductions, Wienerberger demonstrator compared to natural gas burner



**Design point:**

Reductions in absolute values are higher for the Agrana heat pump due to the higher heating capacity. The Wienerberger heat pump was operated at a higher COP. A lower temperature lift was required as the design point was at a lower temperature and the heat source available had a higher temperature. Therefore, the relative reductions are higher. Operation at the design points allow for substantial reduction in energy, emissions, and costs for both heat pumps.

**Operation range:**

During the project, a broad range of operation conditions was tested to thoroughly characterise the behaviour of the heat pumps. When the heat pumps are operated at high temperature lifts, a higher share of electricity is needed, resulting in smaller reductions. Considering Austrian energy prices, operation of the heat pumps is more expensive than the gas burner if the COP is lower than 2.2. Therefore, there were a few operation states that led to a cost increase for both heat pumps. However, emission and energy savings were still realised in these operation states.

Primary energy reduction is calculated with average European factors. If the COP is lower than 1.7, there is an increase in primary energy consumption. Due to the high share of renewable electricity in Austria, it can be assumed that the threshold in Austria is lower compared to European average. There was one operation state of the Wienerberger heat pump with a COP of 1.5, which is non favourable and thus not recommended for further operation.

### 3 OPEN LOOP HEAT PUMP

The open loop heat pump demonstrator, its integration layout and integration infrastructure are described in detail in D4.3 [Integrated Heat Pump System](#). The is designed to be integrated into superheated steam drying processes. Superheated steam is, in many ways, a more superior drying agent than air due to its physical properties, heat, and mass transfer, as well as more efficient penetrability. The heat transfer coefficient of steam is twice of that of air. At the same time, the viscosity (penetrability) of steam is almost half of the viscosity of air. Superheated steam drying therefore has the potential to shorten drying time and energy demand by 20-30%, compared to air drying. The MVR dryer of DryFiciency was developed with this background and under the following considerations:

1. The construction of the dryer ensured that the SHS can be circulated through the dryer and a heating element. This is similar to an air dryer, but the ventilation and heating system were exchanged (steam-fans, steam-heater, etc.).
2. The excess steam must be condensed out by separate condenser. This condenser will substitute air filtration or air handling units.
3. The insulation of the dryer was increased since the drying temperature in SHS is normally higher than in air drying. It was also increased to avoid condensation. The insulation must be sufficient to ensure that no cold bridges cause condensation in the system.
4. The construction of the dryer ensured that as little as possible air or oxygen is present in the system in order to ensure an efficient drying process and to avoid air pockets in the system.
5. The dryer is operated at atmospheric pressure in order avoid expensive pressurized drying chambers and product lock/valves.

The overall layout of the dryer can be seen in Figure 12.

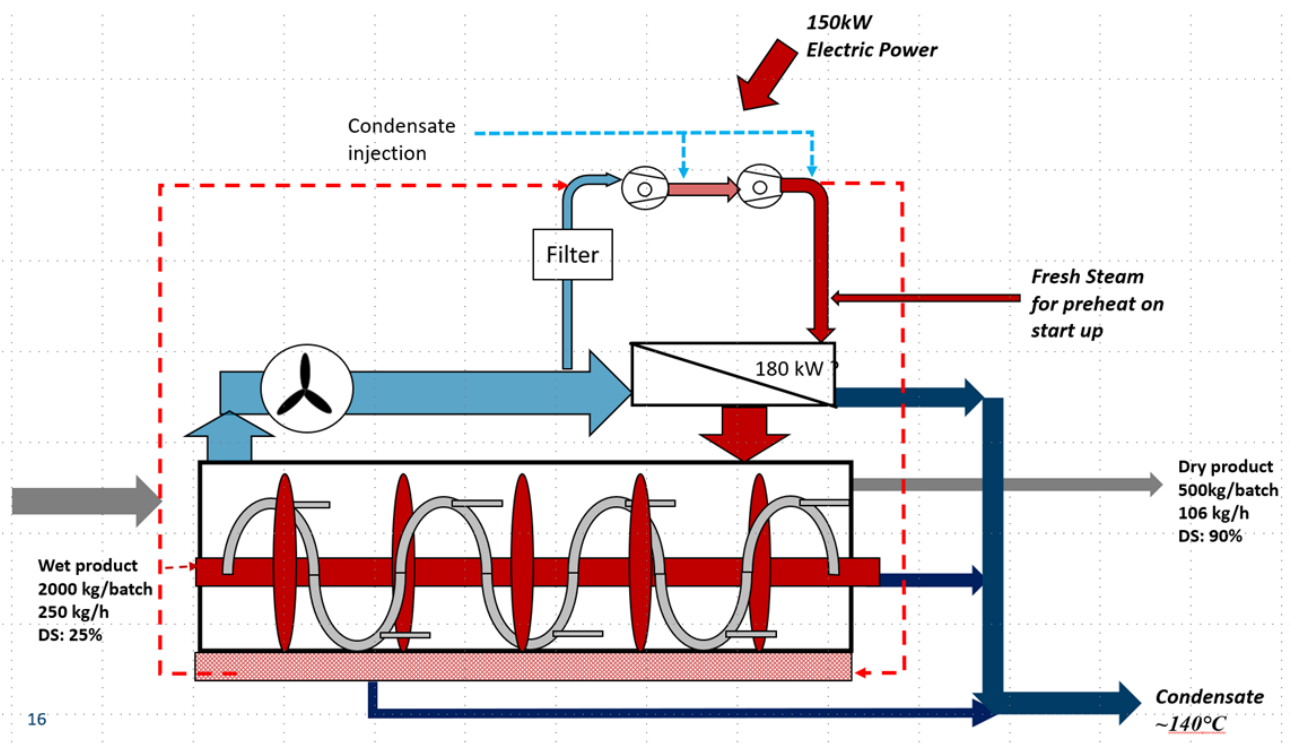

Figure 12: Principle layout of Scanship SHS-dryer as developed in DryFiciency.

The MVR drier is essentially the evaporator of the open loop heat pump system. It generates the steam, which is compressed and then re-used as drying energy for the pilot system. The open loop heat pump system was developed by EPCON Evaporation Technology AS (Trondheim, Norway) and is based on MVR technology. The turbo-compressors used by the open loop heat pump were developed by Rotrex A/S (Copenhagen, Denmark) and a further development of automotive superchargers. The design of the turbo-compressors enables a pressure ratio of 4.2 to 4.7 (depending on pressure losses in auxiliary systems), with a two stage compression system.

Conventional MVR technology will need more stages in series to achieve such high pressure lift. The CAPEX for the capacity range demonstrated in DryFiciency (approximately 1000 kg/hour evaporated water) will be rather high versus the demonstrated Rotrex compressors.

The heat pump operation on-site enables the demonstration of different operation points of the open loop heat pump, which will depend on the temperature requirements of the SHS-dryer. At the highest possible supply temperature of 146°C, the open loop system can provide 494 kW thermal energy at a COP of 4.5. At lower temperatures, the supplied heat will be reduced while the COP is increased up to 8.7 (see Table 4).

Table 4: Performance and COP of the open loop heat pump for different temperature ranges and heat supplies.

Speed	Speed	$m$ at 1 bar	Pressure ratio	$T_{sat}$	$T_{lift}$	Heat delivery	COP	$COP_{Carnot}$	$\eta_{system}$
RPM	%	kg/h	-	°C	K	kW	-	-	%
72000/ 81000	90/90	756	4.23	146	45.6	494	<b>4.54</b>	9.2	49.4 %
68000/ 81000	85/90	648	4.05	144	44.0	423	<b>4.8</b>	9.5	50.4 %
64000/ 81000	80/90	720	3.59	140	39.7	461	<b>5.2</b>	10.4	50.5 %
64000/ 76500	80/85	684	3.44	138	38.2	440	<b>5.1</b>	10.8	47.1 %
60000/ 76500	75/85	648	3.21	136	35.9	413	<b>5.8</b>	11.4	50.5 %
56000/ 72000	70/80	576	2.83	132	31.5	367	<b>6.4</b>	12.8	50.0 %
52000/ 67500	65/75	504	2.49	127	27.3	325	<b>6.5</b>	14.7	44.2 %
48000/ 63000	60/70	360	2.32	125	24.9	226	<b>8.7</b>	16.0	54.7 %

Figure 13 depicts the achieved COPs of the open loop heat pump with data from other industrial heat pumps<sup>11</sup> collected by Arpagaus<sup>12</sup>, that are closed loop heat pumps (labelled “other IHP”). The open loop heat pump achieved an overall efficiency, which is around 50% of the Carnot efficiency (with an assumed heat sink temperature of 140°C). However, the temperature lift is limited to approximately 45 K.

<sup>11</sup> From heat pump manufacturers such as e.g., Kobelco, Viking Heat Engines, Ochsner, Friothersm, Combitherm, GEA, Star Refrigeration, etc.

<sup>12</sup> Arpagaus C, Bless F, Uhlmann M, Schiffmann J, Bertsch S, High temperature heat pumps: Market overview, state of the art, research status, refrigerants, and application potentials, Energy (152), p.985-1010, 2018.

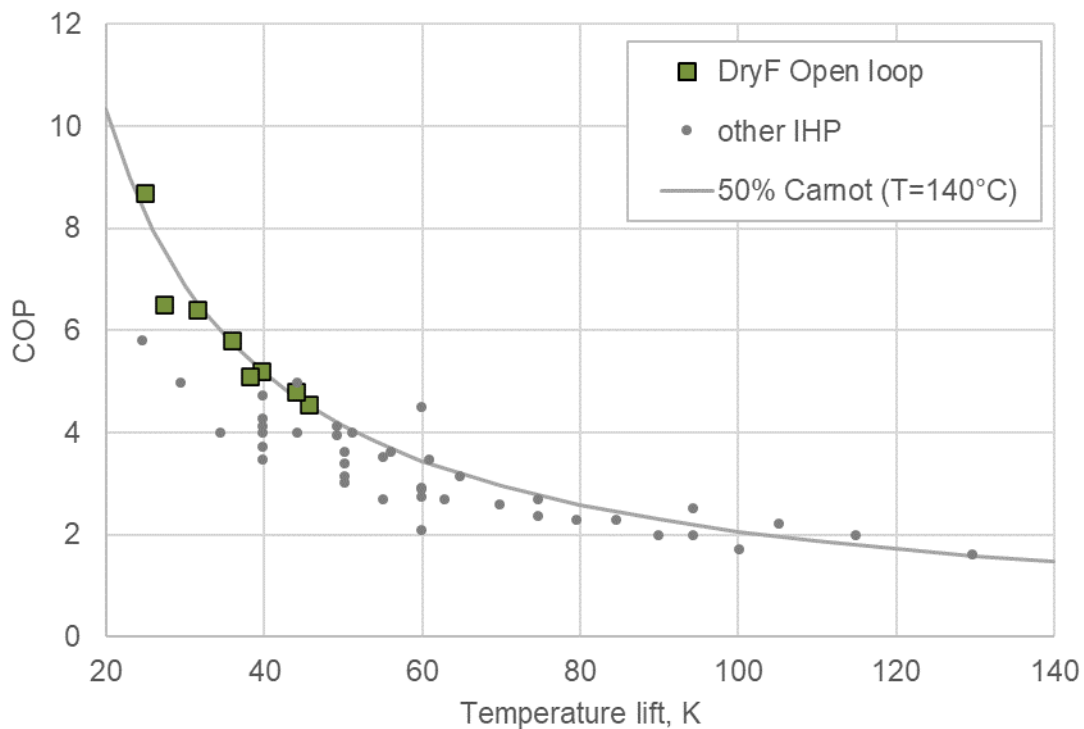

Figure 13: Achieved COP of the DryFiciency open loop heat pump.

Due to the start-up problems between the open loop heat pump and the superheated steam drier (as outlined in [Deliverable 5.4](#)) it was not possible to operate the system together. The start-up problems will be solved post-project.

A fully integrated open loop heat pump system enables an electrified operation of the superheated steam drying system hereby reducing the primary energy consumption by 76%. This reduces, for the open loop heat pump at the Scanship demo site, the CO<sub>2</sub> emissions to almost zero, since 98% of the Norwegian electricity supply is renewable. The energy costs for a system operated with an open loop heat are reduced by 82% based on the current energy prices at the demo site.

## **4 CONCLUSION**

### **4.1 Closed loop heat pumps**

Both DryFiciency heat pumps prove to be a very efficient measure to significantly reduce energy consumption, CO<sub>2</sub> emissions and energy costs. Due to the recovery of waste heat, the heat pump at Agrana consumes 72% less energy than the gas burner. The heat pump at Wienerberger is even more efficient with 82% less energy consumption. The heat pumps are operated on electricity with a high share of renewable energy. Therefore, 73% (Agrana) and 83% (Wienerberger) of CO<sub>2</sub> emissions can be avoided. With the prospect of increasing CO<sub>2</sub> prices for fossil energy carriers, heat pumps also ensure cost effective and future proof process heat supply. Based on current energy prices, a reduction of energy costs by 32% (Agrana) and 56% (Wienerberger) can be realized already now.

### **4.2 Open loop heat pump**

The open loop heat pump system has shown the potential for a significant reduction in energy consumption, CO<sub>2</sub> emissions and energy costs. The recovered and upgrade waste heat (in the form of steam) enables a fully electrified operation the superheated steam drying system hereby reducing the primary energy consumption by 76%. This reduces, for the open loop heat pump at the Scanship demo site, the CO<sub>2</sub> emissions to almost zero, since 98% of the Norwegian electricity supply is renewable. The energy costs for a system operated with an open loop heat are reduced by 82% based on the current energy prices at the demo site.